

動態試驗機

DYNAMIC TESTING MACHINE

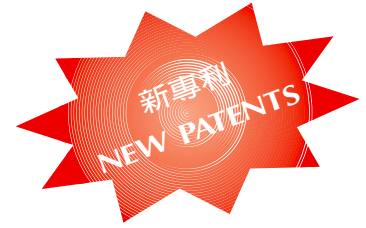

品質、技術、服務



適用行業：金屬、塑膠、橡膠、合成化學製品、汽、機車零件、土木工程、皮革製品、自行車... 等。

DESIGNED FOR TESTING : METAL · PLASTICS · RUBBER · COMPOUND CHEMICAL PRODUCTS · BRIDGE · AUTO PARTS... ETC



● 專利號碼：中國：ZL 99 2 57358.0
台灣：新型第154423號

- 通過ISO-9001國際品質認證
- 獲度量衡國家實驗室認證體系實驗室評鑑認可。
- 力校正實驗室認可編號No:0002，認可證書號碼：CNLA-ZL90275（符合ISO-GUIDE 25）
- 依實驗室認證體系作業程序可核發校正報告書。
- 1995年工業局自動化工程服務機構登錄。



● PATENT NO: ZL 99 2 57358.0 (CHINA)
154423 (TAIWAN)

- QUALITY MANAGEMENT SYSTEM ACCREDITED BY ISO-9001 WITH THE CERTIFICATE NO.Q10161
- DULY APPROVED BY CHINESE NATIONAL LABORATORY ACCREDITATION, REPUBLIC OF CHINA, REF NO. CNLA-ZL90275 (CNLA, ISO GUIDE 25)
- FORCE CALIBRATION LABORATORY REGISTRATION NO.0002
- ISSUE AUTHORIZED CALIBRATION REPORT



弘達儀器股份有限公司
HUNG TA INSTRUMENT CO., LTD

C COMPANY PROFILE

品管儀器的先驅

弘達自1975年9月成立以來，一直秉持著誠意、技術、服務的經營理念，專業於品管儀器的開發與研究。

鑑於「品質管理」是國際性產品的必然趨勢，弘達汲汲於鑽營電腦輔助機械設計及電子計測製造中心，30餘年以來，終於成功開發了將近 1000 種各類的試驗儀器。

弘達研製的試驗機適用之工業包括：橡膠、塑膠、鞋業、造紙包裝業、機械五金業、建材業、汽車零件業、電線電纜業。適用產品如：自行車、摩托車、球拍、球棒、高爾夫球桿、建築五金材料、鋼筋混凝土、橋樑、電線光纖、電纜、紡織、染整，作材料物性檢驗及環境試驗。

弘達也總代理國外數家知名品牌之品管儀器。弘達獲得度量衡國家檢校體系檢校實驗室認可。(力校正實驗室編號：0002)，並可對外校正及檢驗，使產品之精度、技術獲得更高的信賴與肯定。

HUNG TA INSTRUMENT CO., LTD., a pioneer in manufacturing quality control instruments, was established in September 1975. Our CAD-CAM and R&D center is fully equipped to ensure products of advanced technology, state of art knowhow in order to meet our company's strict policy of reliability, tenacity of purpose and good after sales service.

In order to comply with world wide requirement of quality control management, our R&D department has spared no effort in developing up to 200 types of various reliable testing instruments.

Our range of testing equipments are suitable for quality control of products of various fields, including rubber, plastic, shoe manufacturing, paper and pulp industries, machinery and hardware, construction industries, automobile parts, electrical wire and cable. They meet the needs of testing products like automobile, motorcycle, rackets, clubs, hardware items, reinforced concrete, bridge, optical fiber, cable, textile, dyeing and finishing, as well as environmental test equipments.

We also represent a number of reputable quality control equipments manufactured by renown American and European producers.

We are proud to be the only Taiwanese manufacturer approved by the Economic Department of National Calibration and Service Division of Taiwan as an laboratory for inspection and calibration (calibration cert. No.0002). Furthermore, we issue certificates recognized by the government.



· 本公司保有變更設計及外觀色彩的權利，如有更改不另行通知。
· NOTE: The specifications and color of painting are subject to change without prior notice.



合作產品 Joint Product



力校正實驗室及檢測實驗室
The force calibration laboratory & inspection laboratory



電腦軟體及機械設計中心
Computer aided design center



電子計測系統製造中心
Electronic measuring system
manufacturing center



展示測試中心
Show room & testing center



展示測試中心
Show room & testing center



- ▲ 度量衡國家檢校體系力校正實驗室證書及容量0 ~ 2000KN 符合ISO GUIDE 17025
- ▲ Force calibration laboratory approved by CNLA, ISO GUIDE 17025

通過 ISO-9001 國際品質認證，證書號碼 Q10161
Quality Management System accredited by ISO-9001
with the Certification No. Q10161



HT-8756P 電腦式砷化試驗機
Computer Type Disk Rheometer



HT-2101 電腦伺服油壓萬能材料試驗機 (開口式)
Computer-Control Servo Hydraulic
Universal Testing Machine (Openfront-Jaw)



HT-2402 電腦伺服控制材料試驗機
Computer Servo Control Materials
Testing Systems



HT-9770 自動化靜砵碼原級力量標準機
High Precision Automatic Dead
Weight Primary Force Calibrator
(50 KN ~ 2000 KN)

← 2000 KN



← 50 KN

D Type Material Dynamic Tester 動態材料試驗機

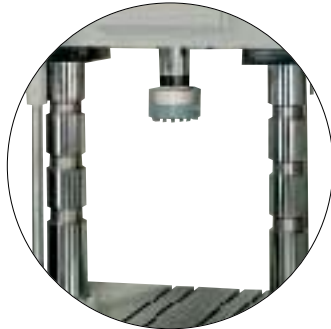

Grip Zoom



E Type Material Dynamic Tester 動態材料試驗機

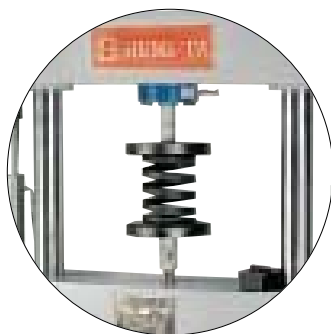

Grip Zoom



Data Acquisition System Block Diagram

資料擷取系統方塊圖

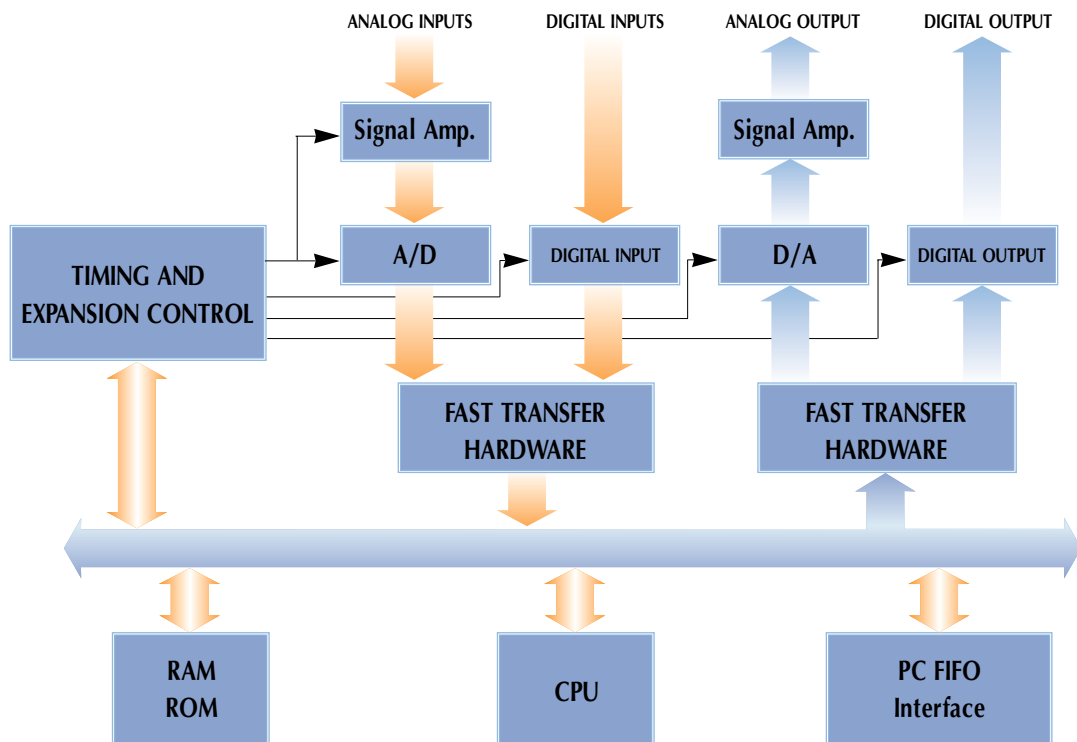

伺服控制軟體 控制功能介紹 (Control Utility)

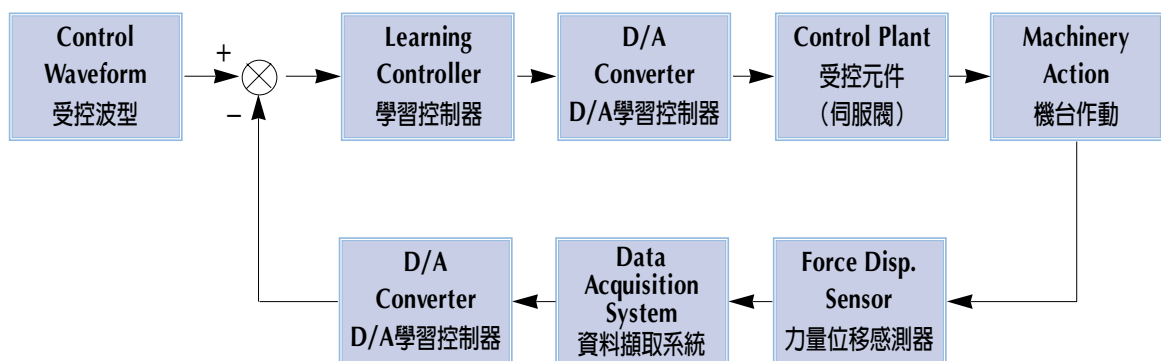

Dynamic Tester Specifications

動態材料試驗機規格

Servo-Hydraulic System Specifications

- 動態電液伺服致動器
- 500~50,000 Kg 出力(可依客戶需求定義)
- 液壓動力單元一組
主泵浦: 流量10~120 L/min, 操作壓力 210 Kg/cm²(option to 310 Kg/cm²)
馬達: 3 Phase, 220 VAC, 60 Hp.(Max)
油箱: 250 L ~800 L容量
高壓過濾器: 5 micron
蓄壓器: 壓力端 1 quart, 回油端 1 quart.(視實際情況決定)
冷卻系統: 1 set
壓力開關: 1 set
聯板位置調定動力單元: 與主液壓動力單元分離, 提供聯板位置調定及鎖定能量
- 伺服閥: 15~180 L/min 額定流量, 頻寬 \geq 50 Hz, 解析度 \leq 0.5%
- 疲勞測試用力量感測元: 500~50,000 Kg容量, 0.05% FS 非線性度, 校正誤差 \leq 1%
- 直流式差動電壓位移感測器(DC type LVDT): 內建於油壓缸內部, 50~300 mm 行程, 0.05%FS 非線性度

Controller and Control Interface Specifications

- 電液伺服致動控制器
- 自學習式閉迴路力量及位置控制器
- 負載及振動控制主題
- 伺服放大器
- 直流感測器訊號處理器
- 類比/數位轉換器: 16 bits 解析度, 1/2 最低位元的非線性度
- 數位/類比轉換器: 16 bits 解析度, 1/2 最低位元的非線性度
- 數位輸出: 程序控制, 機台聯板位置調定
- 電腦配備: 1 set
CPU: Intel Pentium III 800 或更高配備
RAM: 128 MB
15" super VGA 顯示器, 解析度 1024 x 768
硬碟: 10 GB or above
印表機: 噴墨印表機
1.44 floppy driver
儀器櫃 1 set

Servo-Hydraulic System Specifications

- 作業系統: Microsoft Windows[®] 98或以上
- 測試方法資料庫管理
- 定負載調定及行程位置微調
- 自動波形產生 sine, triangular, ramp, and square等波形
- 閉迴路學習控制器控制力量及位移
- 即時圖形顯示
- 測試數據自動儲存, 可完整儲存所有測試過程資料
- 三種圖形放大功能
- 提供力量-時間, 位移-時間, 力量-位移三種圖形顯示功能
- 報表功能: 開放使用者自由編輯
- 報表編輯器
- 控制安全偵測及破壞自動停機
- 圖形尺度可自行定義或自動尺度最佳化

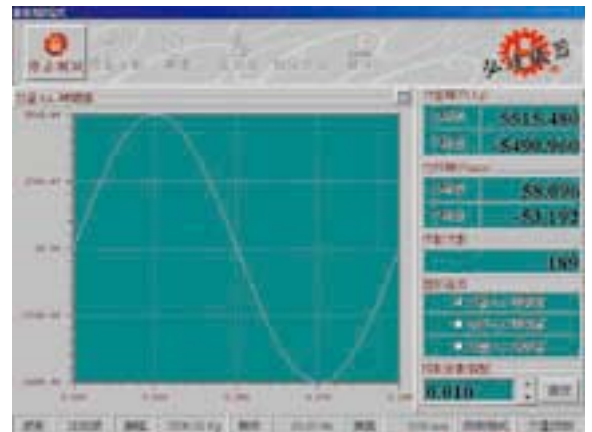

Dynamic Tester Specifications

動態材料試驗機規格

Servo-Hydraulic System Specifications

- One servo-actuator
- 500~50,000 Kg Force (User Define)
- One Hydraulic Power Package
 - Main pump : 10~120 L/min, 210 Kg/cm²(option to 310 Kg/cm²)
 - Motor: 3 Phase, 220 VAC, 60 Hp.(Max)
 - Tank: 250 L ~800 L capacity.
 - Oil Filter : 5 micron.
 - Accumulator : pressure end 1 quart, return end 1 quart.(option)
 - Cooling system : 1 set.
 - Pressure switch 1 set.
 - Crosshead adjustment power package : separate from the main power package, provide power to adjust crosshead position and lock.
- Servovalve : 15~180 L/min rated flow rate, bandwidth \geq 50 Hz(-3 dB), resolution \leq 0.5%
- Fatigue type loadcell : 500~50,000 Kg(5~500 KN), 0.05%FS nonlinearity, calibration error \leq 1%.
- DC type LVDT : built-in-actuator, 50~300 mm stroke, 0.05%FS nonlinearity.

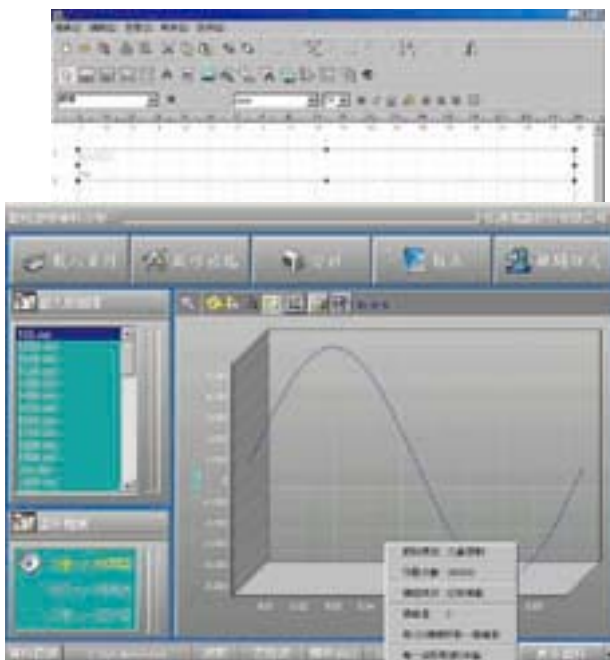

Controller and Control Interface Specifications

- Control one servo-actuator
- Closed-loop force and position learning control.
- Loading and shaking the test article.
- Servo amplifier.
- DC transducer conditioner.
- A/D channel : 16 bits resolution, 3 LSB nonlinearity.
- D/A channel : 16 bits resolution, 3 LSB nonlinearity.
- D/O channel : process control, crosshead position adjustment.
- Computer : 1 set.
 - CPU : Intel Pentium III 800 or above.
 - RAM : 128 MB.
 - 15" super VGA monitor, resolution 1024 \times 768.
 - Hard driver : 10 GB or above.
 - Printer : Inkjet printer.
 - 1.44 floppy driver.
 - Rack 1 set.

Servo-Hydraulic System Specifications

- Operation system : Microsoft Windows[®] 98 or above.
- Set-up test sequence database management.
- Fixture constant load and minor adjustment.
- Auto-generation sine, triangular, ramp, and square wave.
- Closed-loop learning controller, force and position control.
- Real-Time data display.
- Test data auto storage.
- Three kinds graph zooming.
- Provide force-Time, Disp.-Time, Force-Disp. Diagram.
- Present tabular and graphical reports.
- Report editor.
- Auto Stop.
- Control safety diagnostics.
- Diagram auto scale and user define.

HT-9711 動態疲勞試驗機 DYNAMIC FATIGUE TESTING MACHINE

機型	Model		HT-9711-5 落地型		HT-9711-5 桌上型		
動力來源	Power source		電液伺服控制系統 (Electro-Hydraulic Servo Control System)				
最大出力	Force capacity	(Kg) (KN)			500 5		
工作振幅	Max. Stroke (mm)	靜態 (Static) 動態 (Dynamic)			±50 ±25		
控制模式	Control mode		力量控制、行程控制 (force, displacement control)				
靜態力量感測容量	Static force sensor capacity		×120% ×100% · ×50% · ×20% · ×10% · 自倍率選擇 (Auto Gain selection)				
靜態力量感測精度	Static force sensing error		≤ ±1% 校正精度 (Calibration error)				
動態力量感測放大倍率	Dynamic force sensor capacity		100% , ×50% , ×20% , ×10%				
動態力量感測精度	Dynamic force sensing error		≤ ±1% 校正精度 (Calibration error)				
形式	Style		T type				
支柱有效寬度	Operating width(mm)		400				
支柱有效高度	Operating height(mm)		250~900				
外型尺寸	Dimension(cm)		120 (W) × 65 (D) × 220 (H)				
油壓源型式	Hydraulic powetyper		QR-10	QR-20	QR-40	QR-60	QR-80
最小需求流量	Minimum flow rate(l/min)		10	10	40	60	80
伺服閥額定流量	Servo valve rated flowrate(l/min)		15	15	45	80	120
位移感測器	Displacement sensor		1 L / 1 L (選配Option)		5 L / 5 L (選配Option)		
頻率範圍	Frequency range		內建差動電壓計於致動器後端 (LVDT built-in-actuator); 0.05~100Hz 請參閱振幅頻率波德圖				
試驗波型	(Ramp) 正形波(Sine) 三角波(Triangular) 矩形波(Square)						

外形尺寸,工作臺面,行程及噸數可由客戶定義設計,本公司保有修改權利
Dimension, Table, Stroke and Capacity could be customer designed



HT-9711-10	HT-9711-25	HT-9711-50	HT-9711-100	HT-9711-200	HT-9711-300	HT-9711-500
------------	------------	------------	-------------	-------------	-------------	-------------

電液伺服控制系統 (Electro-Hydraulic Servo Control System)

1,000	2,500	5,000	10,000	20,000	30,000	50,000
10	25	50	100	200	300	500

±50

±25

力量控制，行程控制 (Force, Displacement Control)

×120%，×100%，×50%，×20%，×10%，自倍率選擇(Auto Gain selection)

≤±1%校正精度 (Calibration error)

×100%，×50%，×20%，×10%

≤±1%校正精度 (Calibration error)

E type			D type		
530			750		
250~900			250~1100		
980 (W) x 610 (D) x 2350 (H)			1325 (W) x 750 (D) x 2650 (H)		
QR-10	QR-20	QR-40	QR-60	QR-80	
10	20	40	60	80	
15	30	45	80	120	
1 L / 1 L (選Option)			5 L / 5 L (選配Option)		

內建差動電壓計於致動器後端 (LVDT built-in-actuator);0.05~100Hz 請參閱振幅頻率波德圖

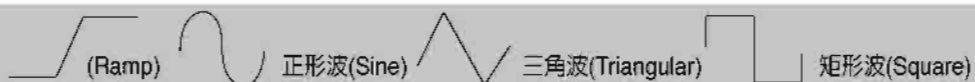

標準配件 Standard Accessories



平板拉力
Tensile for plane



圓棒拉力
Tensile for round



壓縮
Compression

選用配件
Optional Accessories



油壓夾具
Hydraulic Grips

H ydraulic Power Package 動力單元

機型(Model No.)	QR10	QR20	QR40	QR60	QR80	QR120
流量 (L/Min) (60Hz) Flow rate	10	20	40	60	80	120
操作壓力(Kg/cm ²) Operation Pressure	210					
馬達容量(kW) Power(Hp)	5.5 7.5	9.3 15	15.5 25	22 30	30 40	45 60
使用電源Power	ø3, 220V, (50/60Hz)					
冷卻系統形式 Cooling System	水冷式熱交換器 Water Cooling System					
冷卻水流量 (L/min) Cooling water Flowrate	11	20	40	75	100	190

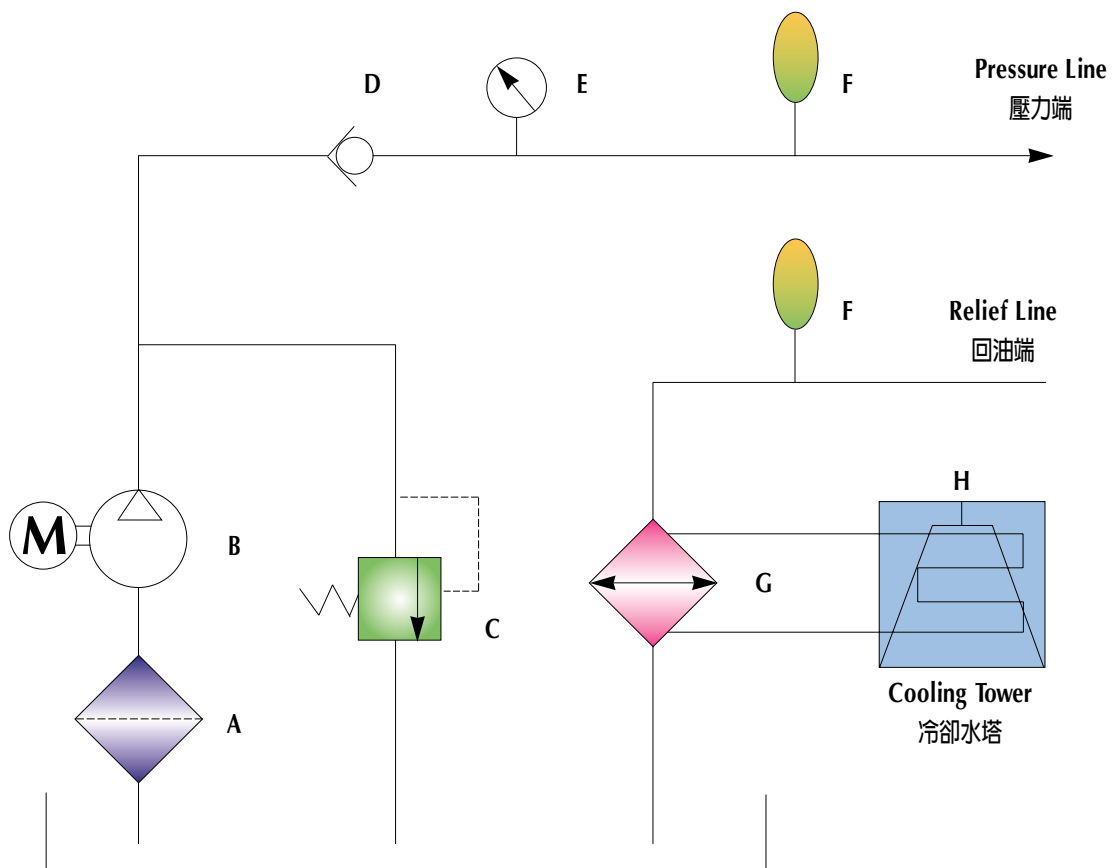

- A. 高壓過濾器 (Filter)
- B. 馬達及幫浦 (Hydraulic Pump and Motor)
- C. 卸載閥 (Relief Valve)
- D. 止回閥 (Check Valve)

- E. 壓力錶 (Pressure Gauge)
- F. 蓄壓器 (Accumulator)
- G. 液壓油熱交換器 (Oil Heat Exchanger)
- H. 冷卻水塔 (Cooling Tower)

H ydraulic Power Package 動力單元

QR-10~QR60



QR-80~QR120



A mplitude v.s. Frequency Bode Plot 振幅-頻率波德圖

HT-9710-25

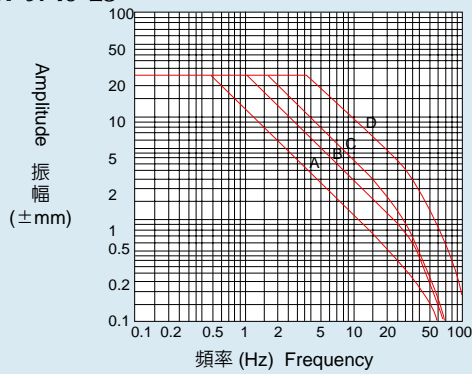

HT-9710-50

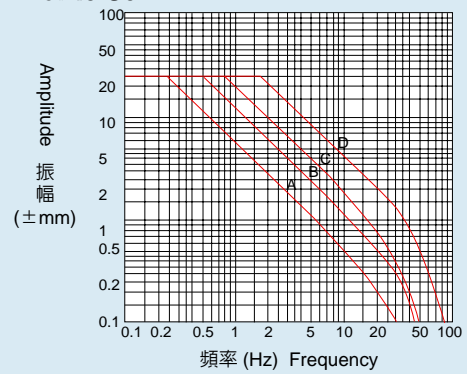

HT-9710-100

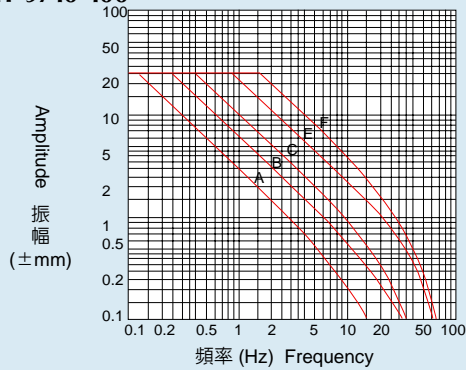

HT-9710-200

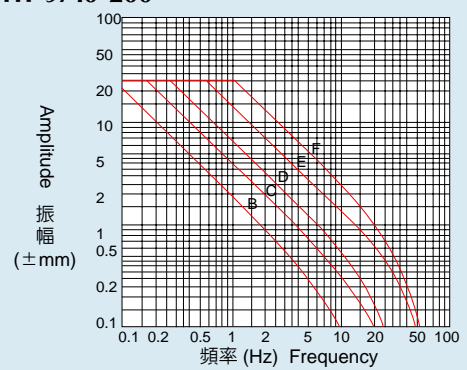

動力單元型號(Power Package)

機型(Type)	A	B	C	D	E	F
油壓源(Power package)	QR-10	QR-20	QR-40	QR-60	QR-80	QR-120

H

T-2110 Dynamic Actuators 動態伺服缸

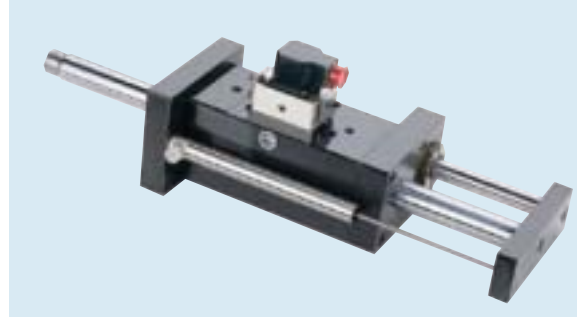

機型(Type)	A-10	A-25	A-50	A-100	A-200	A-500
容量(KN)	10	25	50	100	200	500
Capacity(Ton)	1	2.5	5	10	20	50
行程 Stroke	50(±25)~150(±75)mm					
工作壓力 Working pressure	210kg/cm ²					

G

rips 夾具

標準配件 Standard Accessories

平板拉力
Tensile for plane



圓棒拉力
Tensile for round



壓縮
Compression



選用配件 Optional Accessories

油壓夾具
Hydraulic Grips

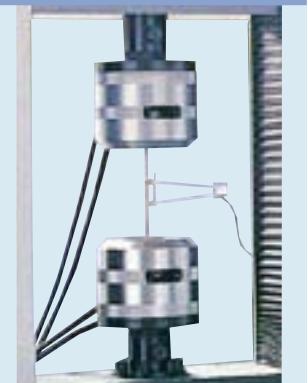

A pplication 應用

(應用夾具價格另議；Applied grips available at extra charges)

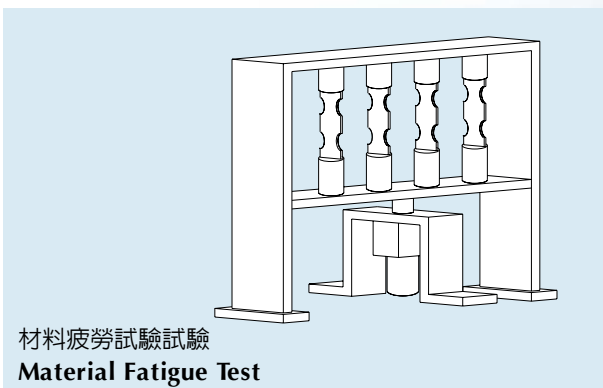
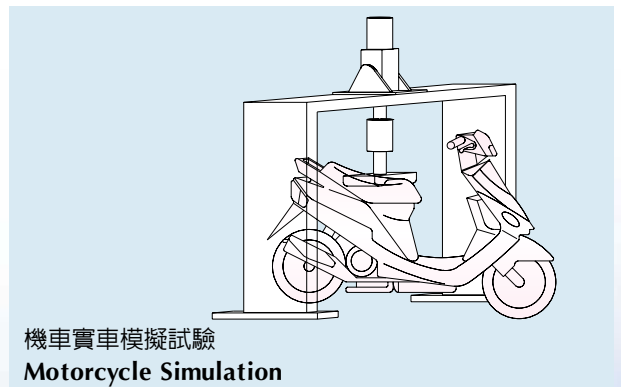
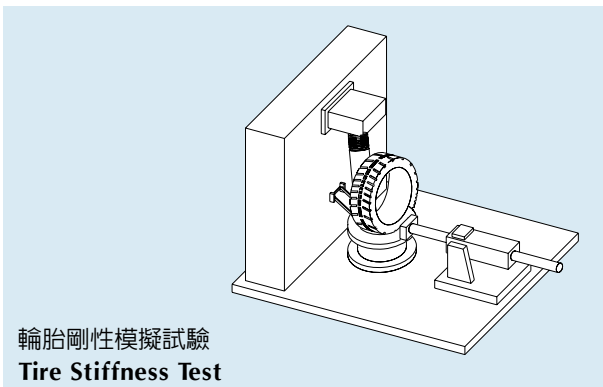
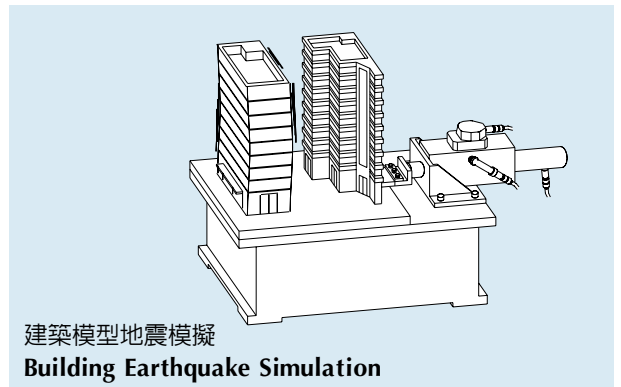
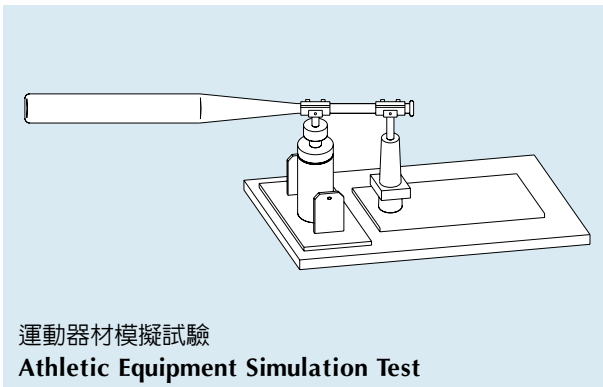
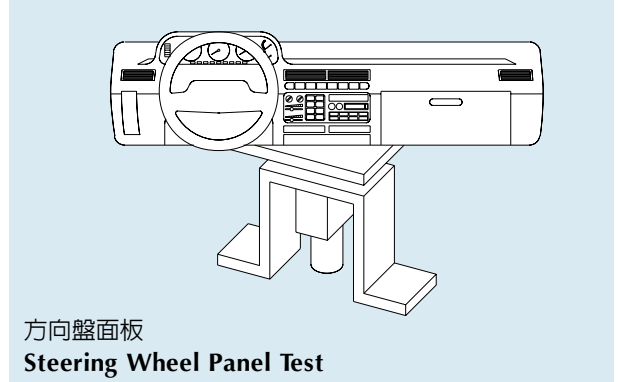
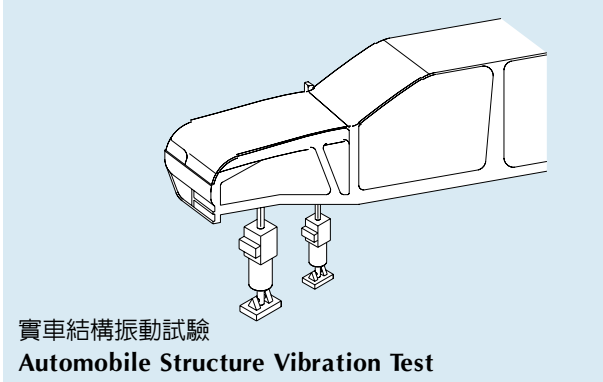



Website : www.hungta.com
www.hungta.com.tw
www.hungta.com.cn

品質、技術、服務

弘達儀器股份有限公司 HUNG TA INSTRUMENT CO., LTD.

總公司 (工廠)

台灣省台中市 407 工業區 11 路 17 號
HEADQUARTERS & FACTORY
No.17, 11th Rd. Industrial Park, 407,
Taichung, Taiwan

TEL: +886-4-23590108 (代表)
FAX: +886-4-23593110, 23588599
E-mail: info@hungta.com

台北分公司

台北市 110 信義區忠孝東路五段
71 巷 17 號
TEL: +886-2-27467770
FAX: +886-2-27686430

高雄分公司

高雄市 807 三民區金山路 305 號
TEL: +886-7-3429618-9
FAX: +886-7-3427499

銷售服務部

弘台達檢驗儀器(上海)有限公司
上海松江榮樂東路 1109 號
TEL: +86-21-57744978 / 57744979
FAX: +86-21-57744978 #609

GLOBAL OFFICES

Thailand Office
泰國公司
TEL: +66-2-3120446-8
FAX: +66-2-3120445

Malaysia Office

馬來西亞公司
TEL: +60-6-7636031
FAX: +60-6-7637692

Vietnam Office

越南公司
TEL: +84-83-7517821
FAX: +84-83-6670254

北京 - 京華輪技術管理顧問(北京)有限公司
TEL: 010-62213252/62211901
FAX: 010-62233597

上海 - 茂聯儀器有限公司
弘萬儀器有限公司
TEL: 021-56954466/56950304
FAX: 021-56377170

東莞 - 東莞市弘揚儀器有限公司
TEL: 0769-22494862/22494895/22494695
FAX: 0769-22494665

廈門 - 台弘達儀器(廈門)有限公司
TEL: 0592-5800710/5800711
FAX: 0592-5800713

莆田 - 莆田市弘泰科技有限公司
TEL: 0594-2683091/2683092
FAX: 0594-2683093

武漢 - 聯絡處
TEL: 027-87332419/87332420
FAX: 027-87332419#12

西安 - 聯絡處
TEL: 139-16350281

沈陽 - 聯絡處
TEL: 138-01002279/138-89148468

本公司保有變更設計的權利，如有更改不另行通知。

Note: The specifications are subject to change without notice.