



品質、技術、服務

## 鞋業專業試驗儀器

Professional Testing Machines  
for Footwear & Related Materials

- 鞋面材料 Upper Material
- 鞋底材料 Outsole Material
- 成品鞋 Whole shoe

*shoe machinery*



# C COMPANY PROFILE

## 品管儀器的先驅

弘達自1975年9月成立以來，一直秉持著誠意、技術、服務的經營理念，專業於品管儀器的開發與研究。

鑑於「品質管理」是國際性產品的必然趨勢，弘達汲汲於鑽營電腦輔助機械設計及電子計測製造中心，30餘年以來，終於成功開發了將近 1000 種各類的試驗儀器。

弘達研製的試驗機適用之工業包括：橡膠、塑膠、鞋業、造紙包裝業、機械五金業、建材業、汽車零件業、電線電纜業。適用產品如：自行車、摩托車、球拍、球棒、高爾夫球桿、建築五金材料、鋼筋混凝土、橋樑、電線光纖、電纜、紡織、染整，作材料物性檢驗及環境試驗。

弘達也總代理國外數家知名品牌之品管儀器。弘達獲得度量衡國家檢校體系檢校實驗室認可。(力校正實驗室編號：0002)，並可對外校正及檢驗，使產品之精度、技術獲得更高的信賴與肯定。

HUNG TA INSTRUMENT CO., LTD., a pioneer in manufacturing quality control instruments, was established in September 1975. Our CAD-CAM and R&D center is fully equipped to ensure products of advanced technology, state of art knowhow in order to meet our company's strict policy of reliability, tenacity of purpose and good after sales service.

In order to comply with world wide requirement of quality control management, our R&D department has spared no effort in developing up to 200 types of various reliable testing instruments.

Our range of testing equipments are suitable for quality control of products of various fields, including rubber, plastic, shoe manufacturing, paper and pulp industries, machinery and hardware, construction industries, automobile parts, electrical wire and cable. They meet the needs of testing products like automobile, motorcycle, rackets, clubs, hardware items, reinforced concrete, bridge, optical fiber, cable, textile, dyeing and finishing, as well as environmental test equipments.

We also represent a number of reputable quality control equipments manufactured by renown American and European producers.

We are proud to be the only Taiwanese manufacturer approved by the Economic Department of National Calibration and Service Division of Taiwan as an laboratory for inspection and calibration (calibration cert. No.0002). Furthermore, we issue certificates recognized by the government.



· 本公司保有變更設計及外觀色彩的權利，如有更改不另行通知。  
· NOTE: The specifications and color of painting are subject to change without prior notice.



合作產品 Joint Product



力校正實驗室及檢測實驗室  
The force calibration laboratory & inspection laboratory



電腦軟體及機械設計中心  
Computer aided design center



電子計測系統製造中心  
Electronic measuring system  
manufacturing center



展示測試中心  
Show room & testing center



展示測試中心  
Show room & testing center



- ▲ 度量衡國家檢校體系力校正實驗室證書及容量0 ~ 2000KN 符合ISO GUIDE 17025
- ▲ Force calibration laboratory approved by CNLA, ISO GUIDE 17025

- 通過 ISO-9001 國際品質認證，證書號碼 Q10161
- Quality Management System accredited by ISO-9001 with the Certification No. Q10161



HT-8756P 電腦式砵化試驗機  
Computer Type Disk Rheometer



HT-2101 電腦伺服油壓萬能材料試驗機 (開口式)  
Computer-Control Servo Hydraulic  
Universal Testing Machine (Openfront-Jaw)



HT-2402 電腦伺服控制材料試驗機  
Computer Servo Control Materials  
Testing Systems



HT-9770 自動化靜砵碼原級力量標準機  
High Precision Automatic Dead  
Weight Primary Force Calibrator  
(50 KN ~ 2000 KN)

← 2000 KN



← 50 KN



# C O N T E N T S

HT-8752	MOONEY VISCOMETER 木尼試驗機	P4
HT-8756P	AUTOMATIC DISK RHEOMETER 電腦式硫化試驗機	P5
HT-2131	MARTINDALE ABRASION TESTER MARTINDALE 耐摩擦試驗機	
HT-8621	ABRASION RESISTANCE (NBS TYPE) TESTER NBS 磨耗試驗機	
HT-8621B	ABRASION RESISTANCE (DIN TYPE) TESTER DIN 磨耗試驗機	P6
HT-2316	MARK II SLIP TESTER 手提式止滑試驗機	
HT-8022	AKRON ABRASION TESTER AKRON 耐磨試驗機	
HT-2302	SHOE ABRASION TESTER 成鞋耐磨試驗機	P7
HT-8031A	DYEING RUBBING TESTER 染色耐摩擦試驗機	
HT-8357	UNIVERSAL WEARING TESTER 萬能磨耗試驗機	
HT-2323	IULTCS RUB FASTNESS TESTER IULTCS 摩擦實驗儀	P8
HT-8360	TABER TYPE ABRASION TESTER 耐磨耗試驗機	
HT-8361	CROCK METER 脫色程度試驗機	P9
HT-2339	SHOE LACE ABRASION TESTER 鞋帶摩擦測試儀	
HT-8213	FLEXING & WATER PENETRATION TESTER 成品鞋防水曲折試驗機	P10
HT-8683	ROSS FLEXING TESTER 耐曲折試驗機	
HT-2301	BENDING TESTER 成鞋耐折試驗機	
HT-2335	WHOLE SHOE FLEXING TESTER 成鞋耐折試驗機	P11
HT-8682	BENDING TESTER 耐彎曲試驗機	
HT-2312	UPPER MATERIAL FLEXING TESTER 鞋面皮伸縮試驗機	
HT-2362	SHOE HEEL-UP BENDING TESTER 成鞋後提彎折試驗機	P12
HT-9492	MAESER WATER PENETRATION TESTER 鞋面皮革動態防水性試驗機	
HT-8643	BALLY LEATHERS FLEXING TESTER 皮革耐撓試驗機	
HT-8021D	Y.S.S. LEATHER BENDING TESTER 皮革屈曲試驗機	P13
HT-8358	SCOTT TYPE CREASE-FLEX ABRASION TESTER 耐撓試驗機	
HT-2364	BALLY WATER PENETRATION TESTER BALLY 皮革動態防水試驗機	
HT-2366	FIBERBOARD FLEXING TESTER 中底纖維板曲折試驗機	P14
HT-2311	WHOLE SOLE FLEXING TESTER 鞋底彎折試驗機	
HT-8021	DEMATTIA FLEX-CRACKING TESTER 彎曲試驗機	
HT-9782	SOLE MOVING AND BENDING TESTER 鞋底走行彎曲試驗機	P15
HT-2363	VELCRO FATIGUE TESTER 黏扣帶疲勞試驗機	
HT-8041K	HEEL IMPACT TESTING MACHINE 鞋跟衝擊試驗機	
HT-8041M	HEEL FATIGUE TESTER 鞋跟連續衝擊試驗機	P16
HT-8058	SAFETY SHOES IMPACT TESTER 安全鞋衝擊試驗機	
HT-8047	AGING OVEN TESTER 老化試驗機	P17
HT-8020A, HT-8020B, HT-8320, HT-8321	BURSTING STRENGTH TESTER 破裂強度試驗機	P18
HT-8043	FREEZING TESTER 耐寒試驗機	P19-20
HT-8247	ULTRA-VIOLET TEST CHAMBER 耐黃變試驗機	
HT-8247A	DISCOLORATION TESTER 耐黃變試驗機	P21
HT-2151	ACCELERATED WEATHER TESTER QUV 耐候試驗機	
HT-8753	OZONE TEST CHAMBER 耐臭氧試驗機	P22
HT-8029	WATER BATH TESTER 恆溫水槽	
HT-8029A	OIL BATH TESTER 恆溫油槽	P23
HT-2360	INFRARED MOISTURE BALANCE TESTER 紅外線水分計	
HT-8136	DAYLIGHT 標準光源箱	P24
HT-8025	PAR MARTON TYPE SPECIMEN ADJUSTER 試片磨平機	
HT-2304	DUAL HEAD SPECIMEN ADJUSTER 雙磨頭磨片機	
HT-2367	RUB FASTNESS TESTER 耐摩擦試驗機	P25
HT-8024F	PNEUMATIC PUNCH PRESS TESTER 氣壓式切片機	
HT-8024	PUNCH PRESS TESTER 試片切片機	
HT-8024D	HYDRAULIC PUNCH PRESS TESTER 油壓式切片機 DUMB-BELL CUTTERS 斬刀	P26
HT-8355	REBOUND RESILIENCE TESTER 反撥彈性試驗機	
HT-8355V	VERTICAL REBOUND RESILIENCE TESTER 垂直式反撥彈性試驗機	
HT-8356	COMPRESSION TESTER OF MAN-MADE SOLINGS 泡棉潛變試驗機	P27
HT-2369	RESILIENCE ELASTICITY TESTER 彈性試驗機	
HT-8354	COMPRESSION AND DEFORMATION TESTER 永久壓縮歪試驗機	P28
HT-2368	IRON NAIL DETECTING TESTER 鐵質針釘檢知器	
HT-2365	SOLE BACKPART STIFFNESS TESTER 皮鞋勾心剛度試驗機	
HT-2380	COMPUTER SYSTEM NON-SLIP PROPERTY TESTER 電腦系統鞋子止滑試驗機	P29
HT-2337	HEEL PULL-OFF TESTER 鞋跟拉脫試驗機	
HT-2322	FINISH HEAT RESISTANCE TESTER 防熱接觸實試儀	
HT-8135	SCORCH TESTER 耐昇華試驗機	P30
HT-2317	LACQUER RESISTANCE TESTER 鞋電阻測試儀	
HT-2318	SHOE DIELECTRIC RESISTANCE TESTER 成鞋耐電壓試驗機	
HT-2336	SOLE ADHESION TESTER 鞋尖剝離試驗機	P31
HT-2303	DIGITAL ADHESION TEARING TESTER 數字剝離儀	
HT-2315	ZIPPER TORSION TESTER 拉鍊扭轉試驗機	
HT-2309	SLIDE FASTENERS RECIPROCATING TESTER 拉鍊往復拉動儀	P32
HT-2319	WATER PENETRATION TESTER 耐滲水試驗儀	
HT-2321	WATER VAPOUR PERMEABILITY TESTER 透氣實驗儀	P33
HT-2324	FREEZING TESTER 防寒試驗儀	
HT-2325	HEAT CONDUCTIVITY TESTER OF FOOTWEAR 隔熱實試儀	
HT-8150A	LOW TEMPERATURE BRITTLENESS TESTER 低溫脆化試驗機	P34
HT-8362D	HYDROSTATIC TESTER 電子式耐水壓試驗機	
HT-8622	HEAT GRADIENT TESTER 熱傾斜試驗機	
HT-8307	STANDARD LAUNDRY TESTER 染色耐洗試驗機	P35
HT-0601	VISCOMETER 黏度計	
HT-8187	BALANCE 電子天平 (比重用)	
HT-8137	PERSPIRATION TESTER 耐汗試驗機	P36
HT-2132A	GRAY SCALE FOR COLOR CHANGE 變褪色灰色標	
HT-2132B	GRAY SCALE FOR STAINING 污染灰色標	
HT-2132C	9-STEP CHROMATIC TRANSFERENCE SCALE 六色九級卡	
HT-8184V	VOICE NAVIGATION & CUSTOM PH METER V 型精密PH酸鹼測定計	
HT-8191	THERMOMETER 表面溫度計	P37
HT-8189	THICKNESS GAUGE 厚度計	
HT-8188HF	HYDRAULIC FRAME TESTER FOR DUROMETER 硬度計油壓試驗基座	
HT-8188MF	FRAME TESTER FOR DUROMETER 硬度計試驗基座	
HT-8188	HARDNESS TESTER 硬度計	P38

## HT-8752 MOONEY VISCOMETER 木尼試驗機

ASTM D1646, BS1673, ISO-289, JIS-K6300  
 AND CNS-10273, 10274

- 本機係用來測試天然橡膠的特性，可測試木尼黏化及木尼燒焦。全電腦控制，可顯示之數值包括TQ3,TQ5,TQ18,TQ35,TS1及TS2。
- The mooney viscometer is specially designed to measure Mooney viscosity and Mooney scorch. It is fully computerized with user friendly software.

## 自動量測系統 AUTO MEASURING SYSTEM

1. 黏度感應器：strain gauge 式傳感器
  2. 木尼黏度值校正：模糊邏輯電腦系統
  3. 手動/自動互換操作系統，學習及操作十分方便
  4. 全電腦式控制，下拉式選單，對話式顯示及控制系統
  5. 測試過程全程監控 - 所視即所得，並可自動計算列印及儲存。可呼叫所需曲線，4+1分鐘的黏度值及橡膠1分鐘的回復特性，橡膠燒焦TQ3, TQ5, TQ18, TQ35, by TS1, TS2 的所需時間。
  6. 測試條件可儲存及呼叫以節省設定時間。
  7. 測試曲線之容許誤差可預設，測試物品質可完全控制。
  8. 可呼叫任何曲線加以比較，並可顯示曲線上任何一點的黏度值。
  9. 多筆測試值可選取並求平均值。
  10. 可根據測試需求終止測試，並求取測試資料 - 或僅僅取消測試。
1. Viscosity detector: strain gauge type transducer.
  2. Calibration of Mooney viscosity value: by fuzzy computer calibration system.
  3. Manual/automatic operation interchangeable, easy to learn and operate.
  4. Full computer control, drop down combo box, conversational display & control system with Chinese/English version.
  5. Monitoring the whole test process. What you see, what you get. Auto calculating, printing and saving. It can recall required curves, the viscosity value of 1+4 minutes, the recovering characters of rubber for 1 minute, the rubber scorch acquiring time of TQ3, TQ5, TQ18, TQ35 by TS1, TS2.
  6. Test terms could be saved and recalled to save the time of setting.
  7. Permitted deviation of test curve could be presetted, and the quality of specimen material would be fully controlled.
  8. It could recall any or some testing curve to compare. And display the viscosity value and time of any point on the curve.
  9. It could choose some testing values and get the average.
  10. It could end test according to test requirements and get the test information, or just to cancel this test.



HT-8752 木尼試驗機  
 MOONEY VISCOMETER

型式 Model	HMV-200
參考標準	ASTM,D1646,BS1673,ISO,R289
Available Standard	JIS K6300,CNS 10723,10274
木尼黏度 Mooney viscosity	最大200M, Max.200M
溫度範圍 Temperature	最大200°C, Max.200 Degree Celsius
壓力系統 Pressure System	空壓 (空氣壓縮機) Pneumatic (Air Compressor)
加熱系統 Heating System	電熱式, Electrical Heater
試片尺寸 Specimen Dimension	約 45x9~12 (直徑x厚度) Approx 45x9-12 mm (dia x thickness)
轉子 Rotor	L 型及 S 型, L type and S type
Rotor Retreating	Automatic
轉子速度 Rotor Rotation Speed	2 +/-0.02rpm
壓盤壓力 Die Pressure	約Approx 1173+/.581kg
驅動馬達 Drive Motor	25w,200/220V,50/60HZ, 1500/1800rpm
電熱片 Heater	嵌入是環狀電熱片, 550W, 2 組 Embedded Ring Heater,550W,2 Sets
選用設備 Optional	列表機, 空氣壓縮機 Printer, Air compressor
工作壓力 Pneumatic Requirements	最大 7kgf/cm <sup>2</sup> (bar), 一般3.8 kgf/cm <sup>2</sup> Max.7 kgf/cm.sq (Bar) Generally 3.8kgf/cm.sq available
外型尺寸 Dimension (W x D x H)	約Approx. 800 x 450 x 1300 mm
重量 Net Weight	約Approx. 259 kg
電源 Power supply	Max.AC220V, 1.2KVA, 50/60HZ

## HT-8756P AUTOMATIC DISK RHEOMETER

### 電腦式硫化試驗機

ASTM D-2084-79, BS1673 PART 10, ISO 3417

- 在傳統的橡膠製造工廠中，師傅經常靠著老練的經驗，調整橡膠配料來迎合模具厚度，或成品軟硬度的要求。雖然經數次的調整，亦可達到目標，但過程中，除了浪費了寶貴的時間與物料外，是否已調得「最佳」配方，則不得而知。如今，藉著電腦軟硬體的協助，由硫化試驗曲線的顯示，可讓一位新手，輕易調得合理的配料與最平衡的焦燒與硫化配方，既節省物料、時間，更可確保品質，一舉數得。此為本機對橡膠工業的最大貢獻。
- 加硫橡膠的最佳開模時間，在大量生產的過程當中，常需與品質控制相結合。本機利用電腦軟體的協助，輔以精密的機械結構，能將各種不同配方的加硫橡膠，求出其最佳開模時間。
- For traditional rubber manufacturing factories, a technician could always adjust the rubber components to meet the moulds' thickness or the hardness of molded products by his own experiences. He can achieve the target through several times of adjustment. However, during the process, not only he spent lots of precious time and materials, but also no one knows if the "best" adjustment for the components is reached. Now, through the help of computer hardware and software, and the test graph of Rheometer, even a fresh operator can easily get the best solution for reasonable components, best-balanced scorch and cure components. Besides saving materials and time, it also assures the quality. It is the best contribution this AUTOMATIC DISK RHEOMETER can do for rubber industry.
- Pre-production quality control plays an important role in rubber industry. With proper control, you can decide the best time for mould opening. This is the reason why Rheometer is gaining more importance in the field of basic research, raw material management, quality control and R&D.

### HT-8756P 規格 SPECIFICATIONS

最大扭力 Max. torque	200 Lbf
扭力感測範圍 Torque. sensing range	25, 50, 100, 200 Lbf-in 4段 stages
溫度範圍 Temperature range	Rt~200°C
溫度控制 Temperature control	電腦控制，PID SCR控制，精度±0.1°C Micro-processor & computer control, PID & SCR control, accuracy ±0.1°C



HT-8756P 電腦式硫化試驗機  
Automatic Disk Rheometer

空壓源 Air source	空壓機選用 Air compressor optional
加熱方式 Heating method	電熱 Electric
溫度檢出 Temperature sensor	PT 100 Ω
轉子 Rotor	高精度加工生產模式 MPC mode (Micro Production Control)
轉子夾持方式 Rotor clamping	空壓 Pneumatic
振動頻率 Vibration disk rotation frequency	100 cpm (1.67Hz)
振動角度 Vibration angle	±1° , ±3° , ±5°
測試時間 Test time	3~600 min 可任意設定 available to set
壓力 Pressure	氣動方式，壓力4.15kg/cm <sup>2</sup> Pneumatic pressure 4.15kg/cm <sup>2</sup>
報告數據 Test data	Ts1, Ts2, Tc10, Tc50, Tc90, ML, MH
扭力校正 Torque calibration	標準扭力校正 Standard Torque Calibration
電源 Power	1Ø, 220V, 50/60Hz
材積 Dimensions	約 about 132(W) x 62(D) x 116(H) cm
重量 Weight	200 kg

## HT-2131 MARTINDALE ABRASION TESTER MARTINDALE 耐摩擦試驗機

### BS-3424, 5690

- 本機係用來測試襯裡、鞋類外層、類織物等相關產品的耐摩擦性。可同時測試四個試片。試片在固定荷重下，以可變化的方向與標準之砂布或砂紙作往復式的摩擦，完成所需之摩擦次數後，再評估其耐摩性之優劣。
- This is used to test the linings, upper materials or some similar samples for their abrasion resistance. Four samples can be tested at the same time. Under constant load, the samples are rubbed repeated against the standard abrasive cloth or paper in all directions. After testing, the sample can be evaluated for its character of abrasion resistance.

荷重 Load	595g, 795g
試片尺寸 Sample size	Ø44 ± 1mm x 4 個pcs
計時器 Timer	六位數LCD數字顯示 6-digit LCD display
計數器 Counter	六位數LCD數字顯示 6-digit LCD display
電源 Power	1Ø, 110/220V, 50/60Hz
重量 Weight	約 about 75 kg
材積 Dimensions	57 x 57 x 32 cm

HT-2131



## HT-8621 ABRASION RESISTANCE(NBS TYPE) TESTER NBS 磨耗試驗機

### ASTM D1630

- 本機係用以測試加硫橡膠或其他橡膠製品混合物料的磨耗程度，如鞋底、鞋跟等。
- This tester is used to test the abrasion resistance of vulcanized rubber or other rubber compounds such as the soles and heels of footwear.

試片數 Specimen	3片 3 Pcs.
轉輪直徑 Diameter of rotation wheel	Ø150mm
試片尺寸 Specimen size	25.4 x 25.4 x 6mm
荷重 Loading	約 Appox. 2265g, 22N/5 (Lbf)
計數器 Counter	6位數LCD數字顯示/三組可各別計數 6 digits LCD display/ 3 sets count individually
迴轉速度 Rotation Speed	45 +/- 5rpm
砂紙粒度 Sand Paper grits	Sand grits # 40
空壓源 Pneumatic source	平均壓力 Average 4kg/sq.cm
電源 Power source	1Ø, 110V or 220V
材積 Dimension (WxDxH)	約 About 71 x 44 x 56 cm
重量 Net Weight	約 About 115 kg

HT-8621



## HT-8621B ABRASION RESISTANCE (DIN TYPE) TESTER DIN 磨耗試驗機

### DIN-53516, JIS-K6369, GB/T9867

- 本機係依DIN標準製造。在磨耗輪滾動的情形下，試件在固定壓力下在覆有砂紙的磨耗輪來回走一次，記錄其磨耗情形。
- The equipment is designed according to "Din Standard". It is applicable to the comparative test of rubber abrasion on the circumference of grinding wheel which is covered with sand paper. The rubber specimen moves longitudinally to and fro on the rotating grinding wheel in order to measure the abrasive rate.

磨耗輪直徑 Grinding wheel diameter	150mm (a Circumference Approx. 400mm)
試件尺寸 Specimen size	Ø16.2mm x Thickness 6-10mm
試件移動速度 Speed of specimen	每轉 4.2mm 4.2mm Per Revolution
荷重 Loading	2.5N, 5N, 7.5N, 10N
磨耗轉速 Grinding wheel rotating speed	40 rpm
傾角 Angle of Dip	3° 試片支撐軸與滾輪垂直夾角 3° Attitude angle of specimen holder and wheel
砂紙粒度 Sand paper grits	#60
電源 Power	1Ø, 110V or 220V
材積 Dimension (WxDxH)	約 About 95 x 33 x 31 cm
重量 New weight	約 About 50 kg

HT-8621B



## HT-2316 MARK II SLIP TESTER 手提式止滑試驗機

### ASTM-F1677

- 本機以水平及垂直分力比值的物理原理來探討試件與地面間的靜摩擦係數。本機為攜帶式設計，並可依需要，做乾式、濕式或受損地面材質的測試，來了解鞋底或鞋跟材料的抗滑特性。
- This tester adopts the theory of horizontal and vertical sub-force to measure the static coefficient of friction between specimen and surface of ground.

荷重 Load	10 Lb
試件尺寸 Specimen size	3" x 3" (76.2 x 76.2 mm)
試件離地板距離 Distance from sample to ground	1/8" ~ 1/4"
支架厚度 Thickness of frame	1.25" (31.8 mm)
底板厚度 Thickness of base board	3/4"
材積 Dimension (W x D x H)	約 About 42 x 20 x 37 cm
重量 Weight	主機 約 10 kg, 測試座 20 kg Main body: about 10 kg, Testing part 20 kg

HT-2316



## HT-8022 AKRON ABRASION TESTER AKRON 耐磨試驗機

### CNS 734 K6264 BS-903-A9 GB/T1689

- 本機係藉由利用砝碼來測試大底輪胎或類似橡膠的產品的耐磨性。
- This tester is specially designed for testing the abrasion endurance of the sole, tire and the rubber-like products in combination with the use of reference weight.

試件尺寸 Specimen	外徑 2.5" 厚度 0.5" 內徑 0.5" 硬度 60~70度或 220(L) x 127(W) x 1.5(T)mm External diameter 2 1/2" Thickness 1/2" Internal Diameter 1/2" Hardness 60~70 degree or 220(L) x 127(W) x 1.5(T)mm
測試速度 Rotation speed	250rpm (BS) 85rpm (CNS) 72rpm (GB)
砂輪 Grinding wheel	Ø150 x 38 (±) #36 (GB), #40 (BS)
測試角度 Adjustable testing angles	0~45 可調, 出廠設定 15° 0~45 Adjustable, manufactured set up 15°
計數器 Counter	6位數LCD數字顯示器 6 digits LCD display
砝碼 Loading	2磅及6磅 Approx. 0.45kg (2 pounds) or 2.73kg (6 pounds)
電源 Power Source	1Ø, 110V or 220V
材積 Dimension	約 Appro 60(W) x 45(D) x 40(H)cm
重量 Net weight	約 Approx. 60 kg

HT-8022



## HT-2302 SHOE ABRASION TESTER 成鞋耐磨試驗機

### GB/T3903.1-94

- 本機係用來測試成鞋鞋底和成型底(片)的耐磨性能。利用旋轉的磨輪垂直壓在試件上，並以一定負荷，一定速度及一定時間對試件進行磨耗試驗，藉以量測試件的磨痕長度。
- This tester is used to measure the abrasion resistance of shoe sole or molded sole. It adopts rotating abrasion wheel vertically pressing on the specimen under a certain load by a certain speed and for a certain period of time in order to measure the length of abrasion track, so as to understand the features of specimen.

磨輪尺寸 Size of abrasive wheel	Ø20 x 4 mm, T12 mm
磨輪速度 Test speed	100 ~ 300 rpm
負荷 Load	4.9 N (特殊要求可在19.6N以內可調) 4.9 N (or optional within 19.6N, adjustable)
天平量程 Weight of Balance	49 N
電源 Power	1Ø, 220V, 50Hz
材積 Dimension (W x D x H)	60 x 50 x 70 cm
重量 Weight	約 About 88 kg

HT-2302



## HT-8031A DYEING RUBBING TESTER

### 染色耐摩擦試驗機

JIS-L0801, 0823, 0849, 1006, 1084, K6328, P8136

- 本機係於錘頭裹以乾或溼之白棉布，再施以砵碼荷重往復摩擦試件。取下白棉布與灰色標比較其灰化程度，藉以判斷試件染色之堅牢程度。
- Cover the rubbing hammer with dry & wet cotton cloth. Fixed requested load on the hammer and then rub the specimen for several times and compare with the gray scale.

試件尺寸 Specimen	22 x 3 cm
白棉布尺寸 White cotton cloth	5 x 5 cm
試驗速度 Rubbing speed	30 cpm
鎚重 Rubbing load	200 g
輔助荷重 Auxiliary load	300 g
摩擦鎚尺寸 Rubbing hammer size	2 x 2 cm/ R45 x 50 mm
摩擦汙染面積 Rubbing damage space	1 cm <sup>2</sup>
摩擦距離 Rubbing distance	100 mm
計數器 Counter	6位數LCD 數字顯示 6 digits LCD display
電源 Power	1Ø, 220V
材積 Dimension (WxDxH)	約 About 50 x 55 x 35 cm
重量 Weight	約 About 58 kg

## HT-8357 UNIVERSAL WEARING TESTER 萬能磨耗試驗機

AATCC-119&120, ASTM D-3886, D-3514, D-3885, DRAFT 20-0-70

- 本機係多用途、高精度、可用來測試表面彎曲及邊端耐磨的特性。可測試的試件包括紡織、皮革、橡膠、塑膠及紙品、乾式、溼式均可測試。
- This machine is of multi-function and high precision for measuring the resistance to surface, flexing and edge abrasion of textile, leather, rubber, plastic and paper. Both wet and dry tests can be done.

拉緊砵碼 Tension Weight	2~1/2 lb, 2~1 lb, 1~2 lb
壓力範圍 Pressure Range	1~9 psi
平衡砵碼 Head Weight	2~1/2 lb, 2~1lb
行程 Table Stroke	約 1" Approx. 1"
表面磨耗頭 Surface abrasion head	1 REV/ Approx. 102 cycles
計數器 Counter	5 Figures
計時器 Timer	30 min
往復速度 Table Reciprocal Movement	120 cycles/min
電源 Power	1Ø, 110V/220V
材積 Dimension (W x D x H)	31 x 65 x 57 cm
重量 Weight	68 kg

## HT-2323 IULTCS RUB FASTNESS TESTER

### IULTCS 摩擦實驗儀

DIN 4843, QB/T 2226

- 本機係利用乾燥或潮濕的白色羊毛布，包在摩擦錘上，往復摩擦在經過染色的鞋面或內襯皮革上，試驗後再觀察其脫色程度或受損的情形。
- This tester adopts dry or wet of white wool felt by wrapping on rubbing hammer with reciprocally rub on dyed shoe surface or inner leather and then observe the situation of fastness or scratch.

試件尺寸 Size of specimen	120 x 20 mm
羊毛布尺寸 Size of wool cloth	15 x 15 mm
摩擦速度 Rubbing speed	40 ± 2 cpm
荷重 Load	500 g
輔助荷重 Auxiliary load	500 g
摩擦距離 Rubbing distance	35 mm
計數器 Counter	6位數LCD 數字顯示 6 digits LCD display
電源 Power	1Ø, 220V, 2.5A
材積 Dimension (W x D x H)	約 About 50 x 35 x 55 cm
重量 Weight	約 About 60 kg

HT-8031A



HT-8357



HT-2323



## HT-8360 TABER TYPE ABRASION TESTER

### 耐磨耗試驗機

CNS 12915-6.17.3, CNS 12915-6.32.3, ASTM-D3884, ASTM-D3690-7.5

- 本機係用於測試紙類、布類、油漆、合板、皮革、瓷磚、橡膠、塑膠等的磨耗試驗。
- 測試時將試件置於迴轉盤，而磨耗輪則加於試件之上，並在磨耗輪上放置規定之荷重砝碼，啟動機器後使磨耗輪和試件相互磨擦，藉此計算試驗前後試件的耐磨耗程度。
- Used to test cloth, paper, paint, plywood, leather, tile, glass, rubber, etc. This machine tests the specimen by rotating the specimen itself while in contact with the grinding wheel, applying the required pressure. The loss of weight reflects the change in weight of the specimen before and after testing.

試件 Specimen	120 x 6.5 x 3mm (EX x IN x H)
砂輪 Grinding wheel	Diameter 2" x 1/2"
測試速度 Test speed	60, 70rpm 可選 two sections
砝碼 Test load	基重 250g , main weight 250g 250, 500, 1000g
計數器 Counter	6位數LCD數字顯示 6 digits LCD display
吸塵器 Vacuum cleaner	110V or 220V
電源 Power	1Ø, 110V or 220V
材積 Dimension (W x D x H)	約 About 35 x 35 x 30 cm
重量 Weight	約 About 30 kg

選擇砂輪 Choice of grinding wheel:				
試片 Specimen	塗料 paint	磁磚 tile	三合板 plywood	塑膠 plastic
砂輪種類 Type of grinding wheel	CS10	CS17	S32	CS17
選配 Optional	CS17		S33	H18, H22
		吸塵器 Vacuum cleaner 110V/220V		

HT-8360



## HT-8361 CROCK METER 脫色程度試驗機

JIS-L0849-I, ISO 105-X12

- 本機係用來測定染色之皮革、鞋面及紡織品在經過一定壓力及一定次數之磨擦後，其所呈現之脫色程度的記錄。
- The apparatus is used to carry out rubbing test and color fastness. The rubbing finger which is wrapped with a white cotton, being moved to and fro at a constant speed, and keeping closely contact with the lower bed. The judgement is made by observing the dirtiness of the white cotton.

型式 Model	(A)電動 Motor	(B)手動 Manual
磨擦桿 Rubbing shaft	2 set	1 set
速度 Rubbing speed	60 CPM	60 CPM
試件尺寸 Specimen	140 x 50 mm	140 x 50 mm
白棉布尺寸 Size of cloth	50 x 50 mm	50 x 50 mm
往復距離 Reciprocated distance	100 ± 1 mm	100 ± 1 mm
磨擦桿直徑 Diameter of rubbing shaft	16 mm	16 mm
砝碼 Load	9N	9N
計數器 Counter	6位數LCD 數字顯示 6 digits LCD display	機械式 Mechanical
電源 Power supply	1Ø, 110V, 6A或 220V, 3A	
材積 Dimension (W x D x H)	約 About 60x46x36cm	約 About 60x20x30cm
重量 Net weight	約 About 80kg (Motor type)	約 About 15 kg (Manual type)

HT-8361A



HT-8361B



## HT-2339 SHOE LACE ABRASION TESTER

### 鞋帶摩擦測試儀

#### SATRA PM93, BS5131: 3.6

- 本機係利用測試鞋帶的耐磨程度。試驗精神為模擬在特定拉力下，鞋帶承受往復的摩擦動作，到規定的次數後停機，或鞋帶斷裂時，記錄其摩擦次數。
- This tester is used to measure the abrasion resistance of shoe laces. It imitates, under a certain tensile force, shoelace undergoes a reciprocal rubbing force, for a certain testing cycles, for until sample fails. Record the rubbing cycles.

夾具間距 Gripping distance	最大310mm, Maximum 310mm
試驗行程 Testing stroke	76mm
試驗速度 Testing speed	100 ± 5cpm
夾具 Grips	6 組 6 sets
荷重砝碼 Load	4.46N x 6pcs
計數器 Counter	6位數LCD 數字顯示 6-digit LCD display
電源 Power	1Ø, 220V, 3A
材積 Dimension (W x D x H)	約 About 65 x 59 x 43 cm
重量 Weight	約 About 65 kg

HT-2339



## HT-8213 FLEXING & WATER PENETRATION TESTER

### 成品鞋防水曲折試驗機

#### STM D813, BS 903, JIS K6301, HG4-836, 837

- 本機係用來測試鞋子的耐浸漬及水中耐曲折等特性，可分為耐浸漬及水中耐曲折兩種功能。測試前先設定所須之時間或次數，到達時則自動停機。鞋內一裝有感應裝置，在有水滲入鞋內時會自動停止計次，並顯示曲折數。
- This is used to determine the character of shoe for its immerse in water or water resistance under flexing test. The flexing cycles or time can be preset and test can stop automatically after it reaches the preset numbers. It is equipped with a sensor inside the shoe so that when water slightly penetrates inside the shoe, the auto counter would stop counting and display the number of flexing.

測試範圍 Testing range	美規童鞋#12~成鞋#13 USA size from #12 for children up to #13 for adults
試片數 Number of sample	2 (分開感測 sensing separately)
彎曲速度 Flexing speed	60/80 rpm 切換 available to switch
彎曲角度 Flexing angle	0~45度可調 0~45 degrees adjustable
試驗室容量 Size of testing tank	15 公升 liters
計時器 Timer	6位數LCD數字顯示 6-digit LCD display
計數器 Counter	6位數LCD數字顯示 6-digit LCD display
電源 Power	1Ø, 110/220V, 50/60Hz
重量 Weight	約 About 81 x 58 x 136 cm
材積 Dimensions	約 About 150 kg

HT-8213



## HT-8683 ROSS FLEXING TESTER 耐曲折試驗機

ASTM D1052, BS5131 : 2.1

- 本機適用於各種橡膠製鞋底、PU等材料，在經過90° 彎折試驗後，觀察其受損及龜裂程度，以判斷材料的優劣。
- Repeated bending of rubber products will develop strain and cracks at right angle and gradually become too weak to be used. The testing method employed in this tester, is to match the conditions of reciprocal bending of sole.

曲折速度 Flexing speed	100 ± 5cpm
曲折角度 Flexing angle	最大 90° Max. 90 degree
試件尺寸 Specimen size	1" ± 0.05(W) x 6"(L) x 0.25"(T)
試件治具 Specimen holder	6 holders
試件數 Available number of specimen	12 pcs.
計數器 Counter	6 位數 LCD 數字顯示 6-digit LCD display
電源 Power	1Ø, 110V 或 or 220V
材積 Dimension (W x D x H)	約 Approx. 70 x 42 x 45 cm
重量 Net Weight	約 Approx. 60 kg

HT-8683



## HT-2301 BENDING TESTER 成鞋耐折試驗機

GB/T3903.2-94

- 本機係用來測試成鞋和鞋底(片)在常溫下的耐折性能。將成鞋或鞋底以一定角度及一定頻率進行一定次數的曲撓試驗，並觀察鞋幫的變化。
- This tester is used to measure the bending resistance of finished shoes or shoe soles under ambient temperature. Bending the sample under a certain angle and certain frequency for a certain cycles, and then check the change of quarter.

測試速度 Test speed	230 ± 10cpm, 0~300cpm 可調 adjustable
彎折角度 Test angle	0~50° 可調 adjustable
計數器 Counter	6位數LCD數位顯示 6-digit LCD display
夾具 Grip	2 只 (1雙) 1 sets
電源 Power	1Ø, 220V, 50Hz
材積 Dimension (W x D x H)	約 About 74 x 64 x 135 cm
重量 New weight	約 About 280 kg

HT-2301



## HT-2335 WHOLE SHOE FLEXING TESTER 成鞋耐折試驗機

ISO 4643, 5423

- 本機係利用長時間、固定頻率及固定角度的方法，以往復的運動方式來測試運動鞋、工作鞋及休閒鞋，觀察其龜裂程度，以了解其耐折性能。
- This tester adopts long duration, fixed frequency and fixed angle to measure the flexing resistance of sport shoes, working shoe and leisure shoes. By observing the condition of cracks, you can understand its flexing resistance.

測試角度 Flexing angle	0~50° 可調 adjustable
測試速度 Flexing speed	140 cpm
試件數 Number of specimen	2 pcs
試件長度 Length of specimen	110~400 mm
試件寬度 Width of specimen	最大150 mm Maximum 150 mm
計數器 Counter	6位數LCD數字顯示 6-digit LCD display
電源 Power	1Ø, 220V, 2.8A
材積 Dimension (W x D x H)	約 About 98 x 76 x 70 cm
重量 Weight	約 About 235 kg

HT-2335

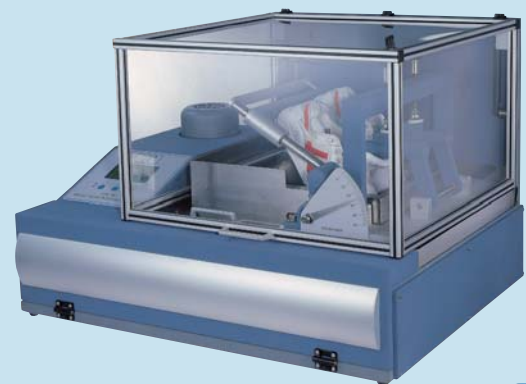

## HT-8682 BENDING TESTER 耐彎曲試驗機

- 本機係用來模擬走路時腳部動作，鞋子受反覆的彎曲效果，來測試成品鞋的品質。
- To ensure the high quality of the finished products, this tester is used for testing endurance of the soles of rubber and plastic shoes after bending repeatedly.

試件數 Capacity	4支, 4 pieces
彎曲角度 Bending Angle	0~90° 可調, 0 to 90 degree (adjustable)
速度 Speed	100 rpm
計數器 Counter	6 位數 LCD 數位顯示 6-digit LCD display
電源 Power Source	1Ø, 110v or 220v
材積 Dimension (W x D x H)	約 Approx. 60 x 40 x 60 cm
重量 Net Weight	約 Approx. 70 kg

HT-8682



## HT-2312 UPPER MATERIAL FLEXING TESTER

### 鞋面皮伸縮試驗機

#### SATRA PM25

- 鞋子於行走過程中，不同部位會受到如拉伸、擠壓、曲折等的受力，造成鞋子材料產生摺痕、皺紋或受損。本機即在模擬此一試驗，作為鞋面材料的品質改善或選購的參考。
- While walking, shoes would withstand different forces such as tensile, squeeze, flexing at different location of the shoes, and which causes the condition of folded, wrinkle or damaged. This machine is to adopt to imitate in order to have a good reference for purchase or quality improvement.

伸縮距離 Flexing distance	19 ± 0.5 mm
伸縮速度 Flexing speed	300 ± 30 cpm
試件尺寸 Specimen size	64 x 64 mm
試件數 Number of specimen	12 pcs
計數器 Counter	6 位數 LCD 數字顯示 6-digit LCD display
電源 Power	1Ø, 220V, 2.5A
材積 Dimension (W x D x H)	約 About 143 x 58 x 66 cm
重量 Weight	約 About 165 kg

HT-2312



## HT-2362 SHOE HEEL-UP BENDING TESTER

### 成鞋後提彎折試驗機

#### ISO 4643, 5423

- 本機係以定頻率、定角度的方式，在長時間的連續往復彎折成鞋後，評估其耐折性能及其龜裂程度。
- 本機適用抬運動鞋、工作鞋及休閒鞋等成鞋測試，且試片可分成兩組，以不同角度，同時進行測試。
- This tester is used to measure the flexing resistance of whole shoe under a certain frequency and angle continuous flexing movement for a longer period of time.
- This tester is suitable for testing sports, safety and leisure shoes. Shoe samples can be tested by two groups with different test angles at the same time.

彎折角度與速度	0~50° 速度 (speed) 50~300 cpm
Test speed and angle	60~90° 速度 (speed) 50~150 cpm
試件數 Number of specimen	4 pcs
最大試件寬度 Max. sample width	150mm
試片最大長度 Max. sample length	150~400mm
計數器	6 位數 LCD 數位顯示
Counter	6-digit LCD display
電源 Power	1Ø, 220V, 50/60Hz, 2.8A
材積 Dimension (W x D x H)	約 About 100 x 80 x 72 cm
重量 Weight	約 About 240 kg

HT-2362

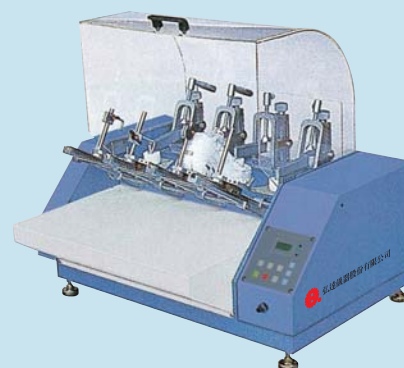

## HT-9492 MAESER WATER PENETRATION TESTER

### 鞋面皮革動態防水性試驗機

ASTM D2099, SATRA PM-34, ALCA E56

- 本機係利用符合標準之鋼珠置於皮革內部，並依此作防水曲折測試。測試前先設定所須之次數，到達時則自動停機。同時本機配備有一感應裝置，在有水滲入時會自動停止計次，並顯示曲折數。
- This is used to test the water penetration resistance of upper leather material under flexing movement by placing standard magnetic steel balls into test sample. The flexing cycles can be preset and test can stop automatically after it reaches the preset numbers. It is equipped with a unique sensing system inside so that when water slightly penetrates inside the test sample, the auto counter would stop counting and display the number of flexing.

測試速度 Test speed	90 ± 5 rpm	
測試位移或角度 Test stroke or angle	1" (ASTM), 30 ± 1° (SATRA)	
試片數 Number of sample	4 組 4pcs	
試片尺寸 Sample size	4" x 4" ± 0.125" (ASTM) 114 x 114 mm (SATRA)	
荷重 Load	鋼珠尺寸 size of steel ball	(1/8" (3mm))
	鋼珠總重 total weight of steel ball	135 ± 5 gs
計數器 Counter	6位數LCD數字顯示 6-digit LCD display	
馬達 Motor	200 W	
電源 Power	1Ø, 220V, 50/60Hz	
材積 Dimension	約 About 76(W) x 50(D) x 45(H) cm	
重量 Weight	約 About 80 Kg	

HT-9492



## HT-8643 BALLY LEATHERS FLEXING TESTER

### 皮革耐撓試驗機

CNS-7705, JIS-K6545, BS 3144, SATRA PM55

- 本機係用來測試在常溫下鞋面皮革、內襯、衣料或袋類材料的耐撓性，測試時以試件的一端表面做為內側，另一端為外側，上下往返將試件彎折至損壞，記錄其次數；或設定彎折次數，再取出觀察其損壞程度。
- This tester is to test the vamp, lining, clothing material, bags & handbags to their flexing resistance. Flexing back and forth till the specimen damaged.

試件數 Flexing grips	12組, 12 sets
彎折尺寸 Bending angle	22.5°
試件尺寸 Specimen size	70 x 45 mm
速度 Speed	100 cpm
計數器 Counter	6 位數LCD數字顯示 6-digit LCD display
電源 Power source	1Ø, 110V或or 220V
材積 Dimension (W x D x H)	約 About 52 x 64 x 40 cm
重量 Net weight	約 About 60 kg

HT-8643

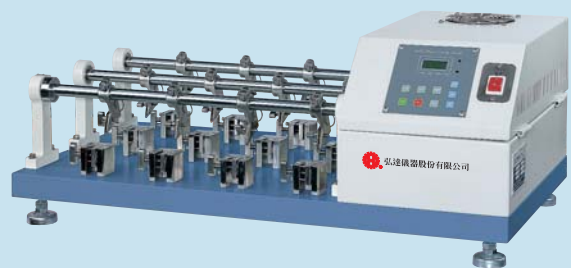

## HT-8021D Y.S.S. LEATHER BENDING TESTER

### 皮革屈曲試驗機

- 本機係用來測試皮革的耐屈曲特性，在屈曲規定的次數後，取下試件，觀察其龜裂或受損情形，據以判斷皮革的品質。
- This machine is used to perform leather bending test. After testing for a certain period of time, observe the leather if cracks or breaks to judge the quality of leather.

測試速度 Test speed	240 r.p.m.
試件數 Flexing grips	12 pcs
試件尺寸 Specimen size	40 x 40 mm
計數器 Counter	6位數LCD數字顯示 6-digit LCD display
馬達 Motor	1/2HP
電源 Power	1Ø, 220V 或or 110V
材積 Dimension (W x D x H)	約 About 56 x 34 x 69 cm
重量 Net weight	約 Approx. 68 kg

HT-8021D



## HT-8358 SCOTT TYPE CREASE-FLEX ABRASION TESTER 耐揉試驗機

JIS L-1005, K-2368

- 本機係用來測試皮革、橡膠、布等材料之耐揉性，施荷重與試件上、夾具間距離及往復距離均可調整。荷重施加方式採彈簧式。
- This machine is to test the crease-flex abrasion resistance on leather, rubber cloth ...ect. The force loaded on specimen, distance between grips and the two-way distance can be adjustable. And the force loaded on specimen is of spring type.

試件尺寸 Specimen size	100 (L) x 25 (W) mm
試件數 Number of specimen	2 pcs
試驗速度 Speed	120 cpm
荷重 Load	0.5 N~50 N
最小刻度 Min. Graduation	5 N
試驗行程 Stroke	0~50 mm 可調 (Adjustable)
計數器 Counter	6位數LCD數字顯示 6-digit LCD display
電源 Power	1Ø, 110V 6A or 220V 3A
材積 Dimension (W x D x H)	約 About 65 x 51 x 30 cm
重量 Weight	約 About 45 kg

HT-8358



## HT-2364 BALLY WATER PENETRATION TESTER BALLY 皮革動態防水試驗機

DIN 53338

- 本機係針對如皮革、人造皮及布料等鞋面材料在有水的環境下，其耐彎折的特性，以作為材料研發，防水加工及品質改善的參考。
- This tester is used to measure the flexing resistance of shoe's upper materials such as leather, symthetic leather and cloth immersed in water in order to be a valuable reference for research, waterproof treatment and quality improvement.

試件數 Number of sample	4 組 4 sets
速度 Speed	60 cpm
行程 Stroke	2, 3, 4, 6 mm 可設定 pre-settable
計時器 Timer	LED, 1~999 hr
計數器 Counter	6位數 LCD 數字顯示 6-digit LCD display
電源 Power	1Ø, 220V 3A 或 or 110V 6A
材積 Dimension (W x D x H)	約 About 55 x 45 x 40 cm
重量 Net weight	約 About 50 kg

HT-2364



## HT-2366 FIBERBOARD FLEXING TESTER 中底纖維板曲折試驗機

QB/T 1472, BS 5131 : 4.2, SATRA PM3, PM4, PM5, PM6, PM15, PM16

- 本機係用來測試皮鞋、休閒鞋及慢跑鞋等中底纖維板的耐曲折特性。試驗方法為在一特定荷重下將試件向左及向右連續各曲折 90° 直到試件破壞時，以其曲折次數作為此中底板的耐曲折指數，以當作中底板的比較和選購的參考。
- This tester is used to test the flexing resistance of fiberboards of insole fore parts. The method of test is to flex the specimen at the angle of 180°C ±90° at each side, reciprocally under a given load. When specimen fails, the flexing times would be the flexing index of the specimen. And this is a good reference for comparing and selecting the material of fiberboards.

HT-2366



上夾具 Upper grip	6個 6pcs
下夾具含砝碼 Lower grip & Load	2kg x 6個
屈折速度 Flexing speed	2kg x 6pcs
試件尺寸 Size of specimen	60cpm
計數器 Counter	80 x 10mm
電源 Power	6位數 LCD數字顯示 6-digit LCD display
材積 Dimension (WxDxH)	1Ø, 220V, 50/60Hz, 3A
重量 Weight	約 About 110 x 30 x 40 cm
	約 About 150 kg

## HT-2311 WHOLE SOLE FLEXING TESTER 鞋底彎折試驗機

EN 344, SATRA TM161

- 本機係用來測試鞋底材料在連續彎折的作動下，其耐彎折的特性。試驗前在鞋底產生最大彎折的地方刺出若干孔，鞋底試件兩端固定於夾具間，試驗時夾具一端固定，一端活動，試件則因機台圓軸之凸動而作彎折動作。試驗一定次數後，在拆下檢視鞋底試件的彎折變化情形。
- This tester is used to measure the flexing resistance of shoe soles under continuous movement. Before test, plunge some holes at the maximum bending position, and affix specimen at both grips, one fixed, one movable. Specimen runs flexing owing to the movement of machine. After a certain test cycles, discharge specimen and inspect how the specimen breaks.

彎折角度 Flexing angle	90°
彎折速度 Flexing speed	125~150 cycles/min
試件數 Number of sample	3 pcs
圓軸直徑 Diameter of mandrel	Ø30 mm
夾具寬度 Width of grips	144 mm
計數器 Counter	6位數LCD數字顯示 6-digit LCD display
馬達 Motor	DC 120 W
電源 Power	1Ø, 220V, 50/60Hz, 3A
材積 Dimension (W x D x H)	約About 105 x 42 x 55 cm
重量 Weight	約About 170 kg

HT-2311



## HT-8021 DEMATTIA FLEX-CRACKING TESTER

彎曲試驗機

JIS K6301, ASTM D813, D430, BS 903

- 將試件置入夾具中以測試試件之耐彎曲特性，可測試之材料包括橡膠、皮革、EVA及大底等。
- Fixed the specimen into the movable grips and flexed the specimen constantly to observe the resistance of cracking.
- In other words to measure its flex-endurance. This machine is suitable for flexing rubber, leather and EVA soles etc.

測試速度 Flexing speed	300 ± 10 cpm
測試間距 Test stroke	19~75 mm
試件數 Number of sample	3 pcs
試件尺寸 Size of specimen	約About 150(L) x 25(W) x 6(T) mm
計數器 Counter	6位數LCD數字顯示6-digit LCD display
馬達 Motor	AC 1/4HP
電源 Power	1Ø, 110V, 6A 或 or 220V, 3A
材積 Dimension (W x D x H)	約About 60 x 35 x 70 cm
重量 Weight	約About 70 kg

HT-8021



## HT-9782 SOLE MOVING AND BENDING TESTER

鞋底行走彎曲試驗機

SATRA PM133

- 本機係用來試驗鞋底材料的在繞著滾筒上之傳動布帶上做循環測試，藉以觀察其耐彎曲的程度。動作是由大輪來的帶動小輪，以轉動傳動布帶。小轉輪有三種尺寸供替換與比較測試結果。
- This tester is used to test the bending resistance of shoe soles affixed on the belt turning by two pulleys. Main pulley drives idle pulley by turning the belt. There are three different sizes for the idle pulleys for replacement and for comparison.

布帶轉速 Belt turning speed	90 cycles/min
布帶長度 Length of belt pulley	1930 ± 50 mm
大輪直徑 Diameter of main pulley	Ø225 mm
小輪直徑 Diameter of idle pulley	Ø60, Ø90, Ø120 mm
計數器 Counter	6位數LCD數字顯示 6-digit LCD display
試件數 Number of sample	Up to 最多6 pcs
馬達 Motor	DC 1/4HP
電源 Power	1Ø, 110V/220V, 50/60 Hz
材積 Dimension (WxDxH)	約About 137 x 62 x 49 cm
重量 Weight	約About 150 kg

HT-9782

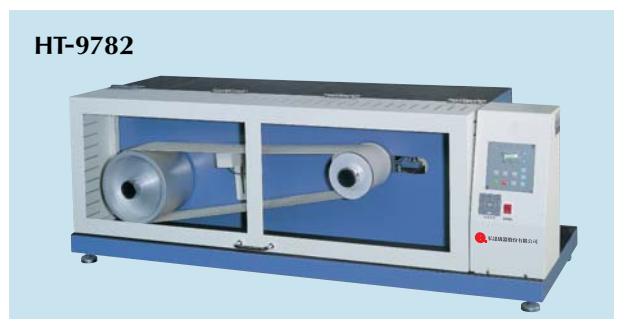

## HT-2363 VELCRO FATIGUE TESTER 黏扣帶疲勞試驗機

DIN 3415 SATRA PM123

- 本機係用來測試黏扣帶（魔術貼）在經過若干次的黏貼及剝離動作後，是否仍具有緊密黏扣的性質。測試時，先以機台做一定次數的黏貼及剝離動作，然後取下試件，截成 75 x 20mm 的尺寸，並以輾壓滾輪均勻滾壓試件，再利用拉力機求其黏貼力與黏貼強度。
- This tester is used to measure if Velcro is still with some bonding capability after some cycles of fasten and peel. First of all, use this tester to fasten and peel specimen to the size of 75 x 20mm. Roll over specimen to make it stick closely by a compressed roller. Then use a tensile testing machine to measure its adhesive force and peeling adhesion strength.

滾輪寬度 Width of roller	70 mm
滾輪直徑 Diameter of roller	上 Upper Ø62.5 mm 下 Lower Ø60 mm
測試速度 Test speed	60 rpm
荷重 Load	5 kgs
計數器 Counter	6位數LCD數字顯示 6-digit LCD display
電源 Power	1Ø, 220V, 50/60Hz, 3A
材積 Dimension (W x D x H)	約 About 75 x 50 x 70 cm
重量 Weight	約 About 60 kg

HT-2363

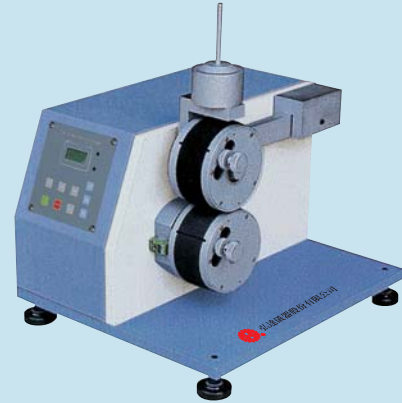

## HT-8041K HEEL IMPACT TESTING MACHINE

鞋跟衝擊試驗機

BS 5131:4.8

- 本機係夾持鞋跟最高的尖端，使鞋跟成垂直狀態，通過擺錘反覆衝擊量測，逐步增加衝擊力，直至鞋跟脫落，讀取衝擊指數。
- This tester is used to measure the impact resistance of heels by clamping the specimen to make the heel stand vertical, let pendulum fall freely to impact on the specimen. Gradually again and again increase the impact force upon the specimen until it fails, and read the impact value.

衝擊容量 Impact capacity	0~18.3J, increase by 0.68J遞增
擺錘規格 Hammer size	Ø108 x 49(t) mm
擺臂規格 Pendulum size	Ø25 mm
擺錘水平時瞬間能量 Momentary energy when hammer is horizontal	17.3N · m (12.7 ft-lb)
錘頭尺寸 Size of hammer head	35(L) x 25(W) x 6(t) mm, R3 圓角半徑
擺錘中心到軸中心距離 Distance between center of pendulum and revolving center	432 mm
試驗座可調範圍 adjustable range of fixture	高度 height 0~80mm, 角度 angle 0~45°
材積 Dimension (W x D x H)	約 About 58 x 38 x 110 cm
重量 Weight	約 About 101 kg

HT-8041K



## HT-8041M HEEL FATIGUE TESTER 鞋跟連續衝擊試驗機

SATRA PM21, BS 5131:4.9

- 本機台是依照BS 5131 第4.9節，鞋跟側面衝擊強度測試之規範予以設計製作。由此規範的衝擊條件可以了解，鞋跟素材承受沖擊能力的範圍。本機可作連續式之破壞試驗。
- This tester is designed and manufactured as per the standard of chapter 4.9 of BS 5131. And this tester is to test the continuous impact resistance of heel material in order to be a good reference of product improvement.

衝擊容量 Impact capacity	0.68J
錘頭尺寸 Size of hammer head	35(L) x 20(W) x 6(t) mm, R3 圓角半徑
擺錘規格 Hammer size	Ø57 x 20(t) mm
擺臂規格 Pendulum size	Ø12.5 mm
X軸調整範圍 X axis adjustable range	40 mm
Y軸調整範圍 Y axis adjustable range	高度 height maximum 80 mm
角度調整範圍 Angle adjustable range	0~45°
擺錘中心到軸中心距離 Distance between center of pendulum and revolving center	152 mm
擺錘中心到衝擊尖端距離 Distance between center of pendulum and striking tip	63.5 mm

HT-8041M



衝擊刃中心與鞋跟頂部距離 Distance between center of impact blade and top of heel sample	6 mm
衝擊速率 Impact speed	60 cpm
衝擊角度 Impact angle	90°
計數器 Counter	6位數LCD數字顯示 6-digit LCD display
馬達 Motor	DC 1/4 HP
電源 Power	1Ø, 220V
材積 Dimension (W x D x H)	約 About 58 x 38 x 61 cm
重量 Weight	約 About 80 kg

## HT-8058 SAFETY SHOES IMPACT TESTER

### 安全鞋衝擊試驗機

CNS6863, CSA, ANSI, EN344, QAS

- 將安全鞋頭置於衝擊區，以特定之能量加以衝擊，檢查其凹陷程度，藉以判斷該安全鞋之品質程度。
- Place the steel head part of safety shoes at the impact area, impact test sample by certain energy. Check how the dent is in order to judge the quality of this safety shoe.

衝擊高度 Impact height	EN 0~1100 mm	BS, ANSI
衝擊重量 Impact weight	20 ± 0.2 kg	22.7 kg
衝擊能量 Impact energy	200 J	100 ± 2 J
衝擊刀刃 Impact blade	R3 ± 0.1 mm	ø25.4 mm
馬達 Motor	DC 1/4 HP	
不斷電系統 UPS	10A, 220V AC	
材積 Dimension	83 x 70 x 204 cm	
重量 Weight	250 kg	
電源 Power	1 phase, 220V, 50/60Hz	

註：EN, ANSI, BS, CSA等規格略有不同，訂購時請注意指定規格。

Note: The requirements between the standards of EN, ANSI, BS, CSA are slightly different, please specify your desired standard.

HT-8058



## HT-8047 AGING OVEN TESTER

### 老化試驗機

JIS K-630, K-7212, ASTM D-2436, E-145, JTTC SPEC.-151 CNS 3556

- 本烘箱係用來研究橡塑膠等試片在固定時間內，以迴轉方式受熱下的變化。在70°C下測試1天，理論上相當於曝露在大氣中6個月的時間，本烘箱配備有馬達驅動式迴轉盤。熱風循環的功能可以確保溫度的均勻分佈。
- The oven is used for degradation study of plastics & rubber when subjected to heat in a rotational condition for a specified time. One day test at 70°C is theoretically equivalent to a six-month usage in normal environmental condition. The machine is equipped with a motor-driven rotary plate. Hot air circulation will ensure even temperature distribution.

型式 Type	A	B
內徑 Inner dimension	40 x 40 x 45 cm	50 x 50 x 60 cm
電熱 Heat	1.8 KW	3.2 KW
溫度 Temperature	RT~200 or 300 degree ceisius	
馬達速度 Motor (speed)	8-10 rpm	
重量 Net weight	80 kg	120 kg
材積 Dimension	84 x 54 x 100 cm	95 x 65 x 118 cm
馬達 Motor	1/4 HP	1/2 HP

HT-8047



**HT-8020A, HT-8020B, HT-8320, HT-8321**  
**BURSTING STRENGTH TESTER 破裂強度試驗機**
**CNS-2054 3479 JIS-L1018, P8112, ASTM-D2210, TAPPI T403ts-63**

- 本機在試驗紙、瓦楞紙板之抗破裂強度，為驗證襪面紙及蕊紙品質不可或缺的設備。
- This tester is used to determine the bursting strength of paper and corrugated board. It is an essential equipment for quality control.

**規格 SPECIFICATION**

Type 型式	HT-8020A	HT-8020B
特點 Features	電子式顯示器 digital display 夾持壓力錶 Clamping pressure gauge	夾具壓力表 Clamping pressure gauge
容量 Capacity	10 MPa	高壓 High pressure 20/50, 50/100 kgf/cm <sup>2</sup> 低壓 Low pressure 6/15 kgf/cm <sup>2</sup> (任選—selectable)
夾持盤直徑 Diameter of clamping	高壓 High pressure : 上 Upper : $\varnothing 31.5 \pm 0.05$ mm 下 Lower : $\varnothing 31.5 \pm 0.05$ mm 低壓 Low pressure : 上 Upper : $\varnothing 30.48 \pm 0.03$ mm 下 Lower : $\varnothing 31.75 \pm 0.25$ mm	
加壓速度 Speed of pressurization	高壓 High pressure : $170 \pm 10$ ml/min 低壓 Low pressure : $95 \pm 10$ ml/min	
顯示精度 Precision of display	0.1 kg/cm <sup>2</sup>	—
退壓速度 Speed of depressurization	高壓 High pressure : $340 \pm 20$ ml/min 低壓 Low pressure : $190 \pm 10$ ml/min	
顯示 Display	Digital Indicator 電子顯示器	3 pcs. of pressure gauge
電源 Power source	1 $\varnothing$ , 110V 6A or 220V 3A	
材積 Dimension	(約 approx) 53cm x 36cm x 63cm	(約 approx) 64cm x 35cm x 50cm
重量 Net weight	(約 approx) 65kg	(約 approx) 65kg

**HT-8020A**

**HT-8020B**

**HT-8320**

**HT-8321**



Type 型式	HT-8320	HT-8320A	HT-8321
特點 Features	鋁合金外觀 Aluminium alloy wrapped 夾持壓力錶 Clamping pressure gauge	電子式顯示 Digital display  鋁合金外觀 Aluminium alloy wrapped 夾持壓力錶 Clamping pressure gauge	鋁合金外觀 Aluminium alloy wrapped  全自動 Automatic
容量 Capacity	2/5, 5/10 MPa (selectable)(任選一)	10 MPa	2/5, 5/10 MPa (selectable)(任選一)
夾持盤直徑 Diameter of clamping	高壓 High pressure : 上 Upper : $\varnothing 31.5 \pm 0.05$ mm 下 Lower : $\varnothing 31.5 \pm 0.05$ mm 低壓 Low pressure : 上 Upper : $\varnothing 30.48 \pm 0.03$ mm 下 Lower : $\varnothing 31.75 \pm 0.25$ mm		
加壓速度 Speed of pressurization	高壓 High pressure : $170 \pm 10$ ml/min 低壓 Low pressure : $95 \pm 10$ ml/min		
顯示精度 Precision of display	—	0.1 kg/cm <sup>2</sup>	—
退壓速度 Speed of depressurization	高壓 High pressure : $340 \pm 20$ ml/min 低壓 Low pressure : $190 \pm 10$ ml/min		
顯示 Display	3 pcs. of pressure gauge	電子顯示器 Digital indicator	3 pcs. of pressure gauge
電源 Power source	1 $\varnothing$ , 110V 6A or 220V 3A		
材積 Dimension	64x35x62 cm(約 approx)	64x35x75 cm(約 approx)	92x34x72 cm(約 approx)
重量 Net weight	80 kg (約 approx)	80 kg (約 approx)	180 kg (約 approx)

**HT-8043**

**HT-8043 FREEZING TESTER**
**耐寒試驗機**
**JIS K6545, ASTM-D1790, D1593**

- 本試驗機適用於橡膠、塑膠、電線PVC鞋底，成品鞋，合成皮革…等之耐寒測試，將材料或成品試樣置入設定低溫之環境室內測試，以瞭解材料或成品適應低溫或寒冷地區的使用情形，確保品質的保證。
- 本儀器低環境室內可依測試需求選擇裝置各種物性彎曲、撓曲、捲彎等機構裝置，配備全部採不鏽鋼製成，並符合各種測試規範標準。
- This tester is used to test the cold resistance for the materials of rubber, plastic, cable sheath, outsole, whole shoe leather and synthetic leather, in order to understand the feathers of those materials under a freezing circumstance. This tester would be excellent equipment for quality improvement.
- Inside the chamber there are many selections available for different test purposes. Please refer to the following table.

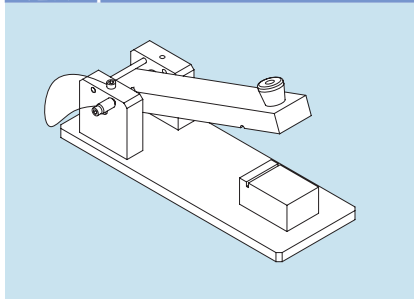
型式MODEL	HT-8043-A	HT-8043-B
溫度範圍 Temperature range	RT~30°C	RT~50°C
環境室內尺寸 Chamber size	60 x 60 x 50	
控溫精度 Temperature accuracy	±0.3°C	
溫度均勻度 Temperature uniformity	±1°C	
降溫能力 Cooling down ability	約需60分 About 60 min.	約需70分 About 70 min.
溫控系統 Temperature control system	電子式數位顯示溫度控制器自動平衡調溫SCR裝置 Digital display temperature controller + automatic balanced temperature system + SCR setup	
冷凍系統 Refrigeration system	全密閉式壓縮機、氣冷式均溫調節控制、壓縮機底溫啟動時間電流保護裝置、環保冷媒規格 Hermetic compressor, air-cooled even-temperature adjusting control, compressor protection setup of startup under low temperature, CFC refrigerant	
機體結構 Chamber structure	內外箱體不鏽鋼材質、採高密度硬質發泡材料、機身結構內部補強堅固 Stainlesssteel SUS#304 plate for interior and exterior, rigid polyurethane foam as insulating material, internally reinforced structure design	
保護裝置 Safety devices	無熔絲漏電超載保護開關、壓縮機過載保護開關、冷媒高壓保護開關、超溫設定保護開關、電磁保護開關 No fuse breaker, compressor overload protection relay, refrigerant high pressure protection switch, over-temperature protector, protection relay	
耗電量 Power consumption	4 KW	6 KW
計數器 Counter	六位數液晶式顯示自動控制 6-digit LCD display	
計時器 Timer	電子式顯示99Hr Digital 999hr/min	
體積 Dimensions	223 x 80 x 90 cm	
重量 Weight	300 kgs (不含撓折配備) (excluding any fixtures)	
電源 Power	1ø, 220V25A	1ø, 220V30A

**H選項 Option H**

**HT-8684 皮革打擊治具 Impact Fixture**

用途Purpose	皮革試件在低溫環境下，以本治具打擊，以觀察是否龜裂。 Impact leather specimen under low temperature and check if it cracks.
符合規範 Standards referred	ASTM D1593
體積 Dimensions	35.5 x 10.3 x 12 cm
重量 Weight	9 kg/組
試驗組數 Number of sample	1組/3組 1set/3sets

## HT-8043常用治具系列 General applicable fixtures

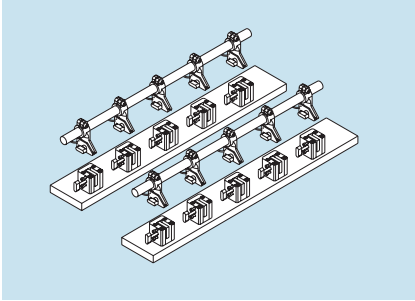
### A選項 Option A (單動作)



#### HT-8643 耐撓治具 Bally Leather Flexing Resistance Fixture

用途 Purpose 皮革試片於低溫環境測試耐撓曲試驗，以檢查撓曲裂痕之品質。  
Flex leather sample under low temperature in order to check the crack of the flexing folding.

符合規範 Standards referred CNC:7705 K-6679, SATRT:PM55, BS:3144, JIS:K6545

撓曲角度 Flexing angle 22.5°

試片尺寸 Size of sample 70 x 45 mm

測試速度 Test speed 100 ± 3 cpm

試片數 Number of sample 10片pcs

### B選項 Option B (單動作)

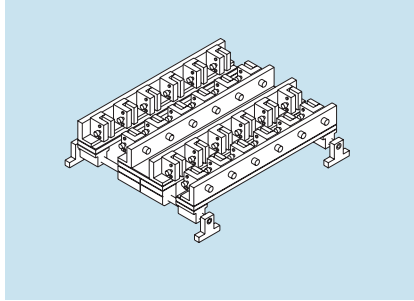

#### HT-8021D YSS鞋面伸縮治具 YSS Leather Bending fixture

用途 Purpose 鞋面皮革試片於低溫環境下，測試伸縮，以檢查皮革伸縮品質。  
Flex upper material under low temperature in order to measure the quality of flexing resistance

伸縮距離 Flexing distance 19 ± 0.5

試片尺寸 Size of sample 64 x 64mm

測試速度 Flexing speed 90 ± 9次/分times/min

測試件數 Number of sample 12片pcs

### C選項 Option C (單動作)

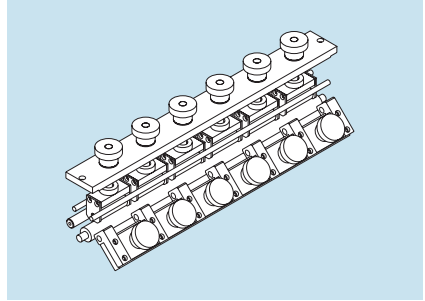

#### HT-8683大底耐曲折治具 HT-8683 Ross Flexing Fixture

用途 Purpose 皮革試片於低溫環境下，經ROSS裝置測試耐折90度，以查皮革耐折品質。  
Put leather sample under low temperature and flex the samples with Ross fixture downwards for 90 degrees in order to check the quality of flexing resistance.

符合規範 Standards referred ASTM-D-1052

耐折角度 Test angle 90°

測試速度 Test speed 103 ± 3次/分times/min

測試件數 Number of samples 6組sets (12片pcs)

### D選項 Option D (二動作)

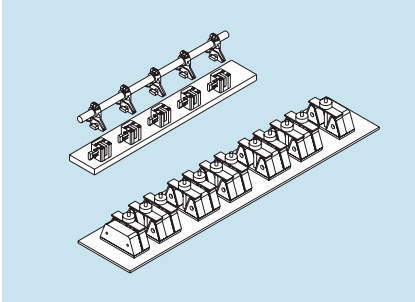

#### HT-8643 皮革耐撓治具+ HT-2312 鞋面皮伸縮治具 HT-8643 Bally Leather Flexing Fixture + HT-2312 Vamp Flexing Fixture

用途 Purpose	皮革耐撓 Leather flexing	鞋面皮伸縮 Vamp flexing
符合規範 Standards referred		SATRA PM117
耐折角度 Test angle	22.5°	40°
測試速度 Test speed	100次/分 times/min	300 ± 30次/分 times/min
測試件數 Number of samples	5組sets	12片pcs

### E選項 Option E (二動作)

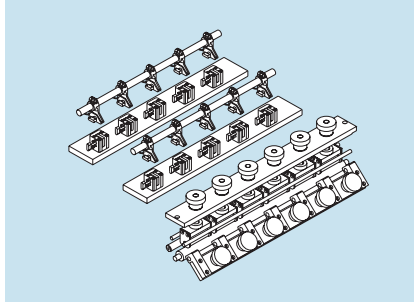

#### HT-8643 皮革耐撓治具+ HT-8683大底耐曲折治具 HT-8643 Bally Leather Flexing Fixture + HT-8683 Ross Flexing Fixture

用途 Purpose	皮革耐撓 leather flexing	大底耐曲折 Ross flexing
符合規範 Standards referred		ASTM/D/1052
耐折角度 Test angle	22.5°	0~90°
測試速度 Test speed	100次/分 times/min	
測試件數 Number of samples	10組sets	6組sets 12片pcs

### F選項 Option F (二動作)

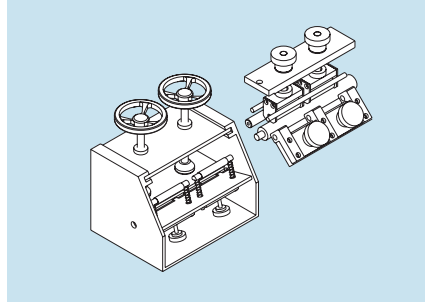

#### HT-8682 成鞋耐彎曲治具+ HT-8683大底耐曲折治具 HT-8682 Bending Fixture + HT-8683 Ross Flexing Fixture

用途 Purpose	成鞋耐彎曲 Bending	大底耐曲折 Ross flexing
耐折角度 Test angle	0~90° 可調adjustable	
測試速度 Test speed	100次/分times/min	
測試件數 Number of samples	2組sets	2組sets (4片pcs)

### G選項 Option G (三動作)

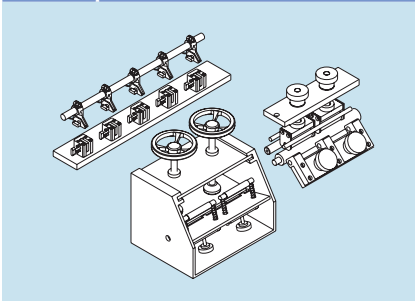

#### HT-8643 皮革耐撓治具+ HT-8682 成鞋耐彎曲治具+ HT-8683大底耐曲折治具 HT-8643 Bally Leather Flexing Fixture + HT-8682 Bending Fixture + HT-8683 Ross Flexing Fixture

用途 Purpose	皮革耐撓 Leather flexing	成鞋耐彎曲 Bending	大底耐曲折 Ross flexing
耐折角度 Test angle	22.5°	0~90° 可調adjustable	
測試速度 Test speed	100次/分 times/min		
測試件數 Number of samples	5組 sets	2組 sets	2組 sets (4片pcs)

## HT-8247 ULTRA-VIOLET TEST CHAMBER

### 耐黃變試驗機

- 成品鞋出口運輸途中，係置於貨櫃中，因受太陽輻射影響，鞋材易於與其所含之化學成份產生作用，致使鞋子之色澤產生變化。本機係模擬太陽光中之紫外線，測試鞋材之耐黃變特性，以利其製程中，化學品添加量管制的參考。一般測試參考時間為三小時，相當於在貨櫃中3個月。
- 本機內外箱皆採不銹鋼材質，並附試件架及空間循環裝置，確保試件受熱均勻。
- Owing to the transportation of shoes in the container for export, heat radiation directly cast on the finished products, causing chemical reaction which results in shoes fading or discoloring. Test of three hours in the chamber is equivalent to the time of holding in the container for 3 months long.
- This tester is made of stainless steel both inside and outside with a sample rack and designed with air circulation device.

光源 Light source	UV燈管 15W x 2支 Tube
內徑 Test chamber size	46 x 30 x 35 cm
計時器 Timer	4位數，可設定時、分、秒 4 digits available to set at hour, min or sec
電源 Power source	1Ø, 110V or 220V
紫外線燈管 Ultraviolet light	15w. 2 pieces
測試距離 Testing distance	150~250 mm
內外箱材質	不鏽鋼
Inner and outer of the chamber	Stainless steel
試片架 Sample rack	1組 One set
材積 Dimension	65 x 40 x 45 cm
重量 Net weight	約 Approx. 15 kg

HT-8247



## HT-8247A DISCOLORATION TESTER 耐黃變試驗機

### ASTM-D1148

- 成品鞋出口運輸途中，係置於貨櫃中，因受太陽輻射影響，鞋材易於與其所含之化學成份產生作用，致使鞋子之色澤產生變化。本機係模擬太陽光中之紫外線，測試鞋材之耐黃變特性，以利其製程中，化學品添加量管制的參考。一般測試參考時間為三小時，相當於在貨櫃中3個月。
- 本機係以德製UV燈泡作為光源，並控制其箱內溫度，提供業界更為精確、詳實的參考。
- Owing to the transportation of shoes in the container for export, heat radiation directly cast on the finished products, causing chemical reaction which results in shoes fading or discoloring. Test of three hours in the chamber is equivalent to the time of holding in the container for 3 months long.
- This tester uses UV light bulb (made in Germany) for light source to control the temperature inside of chamber. This is a good reference of explication and accuracy in shoe's field.

光源 Light source	300W UV燈泡 Lamp
迴轉盤尺寸 Specimen pan	Ø45 cm (revolving)
迴轉盤速度	0~50 r.p.m. (adjustable)
溫度 Temperature	Rt~200°C
加熱方式 Heating method	熱風循環式 Hot air circulation
隔熱層 Heat holding layer	玻璃纖維 Glass fiber
光度 Light irradiance	可調 Adjustable
計時器 Timer	0~24小時 0~24HR
馬達 Motor	1/4 HP
內徑 Internal	50 x 50 x 60 cm
材積 Dimension (W x D x H)	95 x 65 x 113 cm
重量 Weight	95 kgf
電源 Power	1Ø, 220V

HT-8247A



## HT-2151 ACCELERATED WEATHER TESTER QUV耐氣候試驗機

ASTM G53, D4587, D4799, ISO 4892, SAE J2020, BS 27282

- 美製QUV耐氣候試驗機係模仿大自然界之天然條件，來測試各種物料對大自然惡劣氣候條件之精密儀器。為本機之模擬可縮短實際曝曬於大氣中之時間，可提前了解試片長期在大自然中老化、褪色、氧化、龜裂、剝落、衰竭等現象，對於產品的品質控制及研發、改善等有極重要之參考價值。
- This QUV weather tester (made in USA) is to imitate the natural condition of climate in order to understand the weather resistance for the samples exposed in the normal circumstance for a long time. This would be helpful for us to be able to make out in advance how the samples would get aged, fade, oxidation, crack, blister, deteriorate...etc. This would be a very useful and important for quality control for product development and improvement.

型式 Type	QUV 2000 / SPRAY	QUV 2000
UV照射 UV exposure	.	.
觸控式螢幕 Touch screen panel	.	.
冷凝 Condensation	.	.
光照控制 Irradiance control	.	.
可調光線 Adjustable irradiance	.	.
噴水 Water Spray	.	.
自我偵錯功能 Self-diagnostic function	.	.
輻射計 Calibration Radiometer	選配 Optional	
試片數 Number of sample	46片 pcs (75×150mm) + 黑盤溫度計 Black panel thermometer	
溫度範圍 Temperature Range	UV 溫度temp. 冷凝溫度 condensing temp.	50~80°C 40~60°C
紫外線燈管數 Number of UV lamp	8 pcs, (備用4支 4 pcs for spare)	
用水種類 Source of water	蒸餾水 Distilled water	
耗水量 Water consumption	7公升/分 liter/min	8公升/日 liter/day
電源 Power	1Ø, 220V, 50/60Hz	
重量 Net weight	約 About 155 kgs	
材積 Dimension	約 About 135×51×155 cm	

HT-2151



## HT-8753 耐臭氧試驗機 OZONE TEST CHAMBER

ASTM D1149, D1171, D3041 / ASTM D470, D1352, D1373

- 本機係用來測試在臭氧的環境下，橡膠製品耐龜裂的特性。
- The chamber is used to determine the crack resistance for rubber products under ozone circumstance.

型式 Model	0500	0500A
臭氧濃度範圍 Ozone range	0-250 pphm/vol.	50-300 ppm/vol.
系統精度 System accuracy	量測讀值 3% of reading, 控制設定 4% of set-point	
溫度 Temperature	Up to 90°C 以上	
適用標準 Applied standards	ASTM D1149, D1171 D3041	ASTM D470, D1352, D1373
內部空間 Net oven dimensions	61×51×46 cm	
臭氧產生方式 Ozone generator	紫外線 Quartz Ultra Violet	靜電弧放電 Silent Arc Discharge
箱內空氣速度 Oven air velocity	In excess of 2 feet/sec以上	
入室空氣流量 Inlet air flow	0-6 cfm	10-20 cfh
附件 Accessories	Static stretching apparatus 靜態拉力夾具×4組 sets	
電源 Power	1Ø, 220V, 50/60Hz	
重量 Weight	182 kg	186 kg
材積 Dimension	122×64×84 cm	

HT-8753

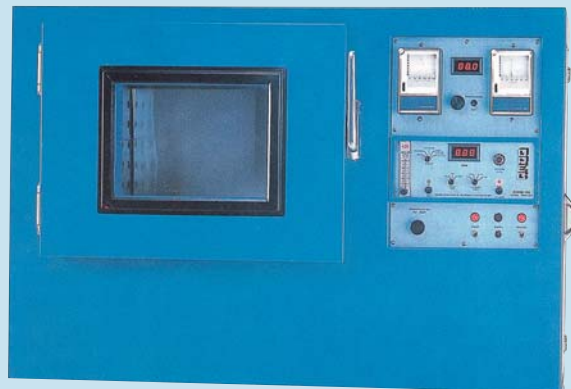

## HT-8029 WATER BATH TESTER 恆溫水槽

CNS-3143, 740, 3479; ASTM-D1693

- 本機適用於漆包線、絕緣被覆體等材料之耐水性試驗。
- 將試件浸於熱水中一段時間，再取出試件，以研究其劣化情形，如起泡、退色、膨脹等等。另外，在相同條件下亦可檢查試件重量的變化。
- This tester is used to test the water resistance of the material such as enameled copper wire, insulating sheath ...etc.
- Within a certain period of time, the specimen is being soaked in the hot water in order to study the degenerating condition such as blistering, fading, swelling, etc. In addition, the test method is expected to further calculate the changes in weight while under such as condition.

型式 MODEL ITEM	HT-8029
溫度 Temperature	Rt~100°C
容量 Bath capacity lid opening	30 x 30 x 20 cm
材積 Dimension (W x D x H)	65 x 43 x 35 cm
重量 Net weight	約 Approx. 17 kg
電源 Power source	1 phase, 220V

HT-8029



## HT-8029A OIL BATH TESTER 恆溫油槽

CNS 687, 689, 3985, 3986, 3987

- 本機適用於漆包線、絕緣被覆體等材料之耐油性試驗。將試件浸於熱油中一段時間，再取出試件，試驗其拉力強度。如試件係漆包線，亦可檢查其漆包塗膜的品質。
- This machine is used for testing the enameled copper wire, insulator or sheath that are made of rubber or plastic. Soak sample in warm oil after a given period of time and then take out specimen for testing its residual rate of tensile. If the sample happened to be enameled wire, you can detect the quality of its varnish film.

## HT-8029A 規格 SPECIFICATIONS

型式 Model	C type	D type
試件 Applied	啞鈴型試片 Dumbbell sample	漆包線 Enameled copper wire
試料數 Sample volume	試杯×6 test cups, ø5×15 (深 depth) cm	試驗槽 Test bath 30×30×20 cm
溫度 Temperature	Rt~300°C	
攪拌馬達 Mixer	25W	
材積 Dimension	65(W) x 43(D) x 35(H) cm	
重量 Weight	約 Approx. 20 kg	約 Approx. 17 kg
電源 Power	1ø, 110/220V, 50/60Hz	

可接受特殊尺寸訂製 Different inner size available upon request at extra charge.

HT-8029A

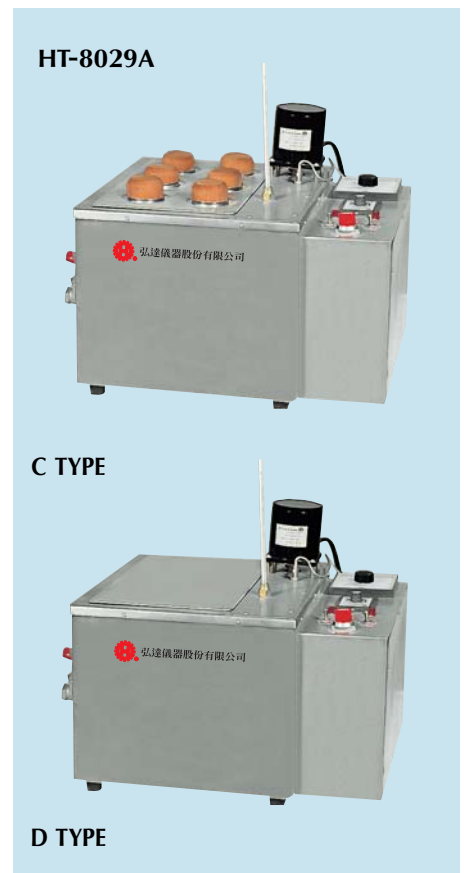

C TYPE

D TYPE

## 試驗規格 TEST SPECIFICATIONS

材料 Material	橡膠外皮 Rubber sheath	塑膠絕緣被覆體 Plastic insulator or sheath	漆包線 Enameled copper wire
試驗油 oil	CNS 3562 #2潤滑油 #2 lubricant of CNS 3562 (須由客戶自備 responsible by client)		CNS 1326絕緣油 Insulating oil of CNS 1326 Test (須由客戶自備 responsible by client)
試件規格 Specimen size	#3 或 #4啞鈴型試片 Dumbbell sample		長度 length: 20cm
試驗時間 Test time	1.8 hrs	4 hrs	24hrs
試驗溫度 Test temperature	120°C	70°C	100°C
浸泡深度 Soaking depth	-	-	15cm

## HT-2360 INFRARED MOISTURE BALANCE TESTER

### 紅外線水分計

- 本機種是用來測定材料中的含水量，不但以數字顯示，清晰易讀，更有可自動扣除毛重之功能，深獲塑膠相關行業的青睞與選購。
- This tester is used to measure the moisture content for various materials, especially for plastic grains. This tester is not only convenient for reading upon digital display, but also equipped with the function of auto tare subtraction. This tester is widely adopted by the plastic-related field of industries.

測定範圍 Measuring range	水分 0-100%，濕基準 Moisture 0-100%, wet based method
精度 Accuracy	取樣重量10g或以上時: $\pm 0.1\%$ 取樣重量為 5~10g時: $\pm 0.2\%$ $\pm 0.1\%$ , when sampling weight is 10g or above $\pm 0.2\%$ , when sampling weight is 5~10g
熱源 Heat source	185W 紅外線燈 infrared lamp
測定方式 Measuring method	加熱乾燥重量測定方式 By measuring weight after heated and dried
試件重量 Weight of specimen	5~70g, 可隨意取樣
重量讀取極限 Limit of weight reading	10 mg
顯示方式 Display method	LCD數字式液晶顯示, 最小顯示值0.1% by digital LCD display, minimum reading 0.1%
試件盤 Specimen pan	不銹鋼製 Made by stainless steel
附件 Accessories	185W 紅外線燈x1, 鋁箔紙 185W infrared lamp x1, aluminum sheet
電源 Power	AC100~240V, 50/60Hz
材積 Dimension	210(W) × 320(D) × 318(H) mm
重量 Net weight	約 About 5 kg

HT-2360



## HT-8136 DAYLIGHT 標準光源箱

### JIS-Z8724, IEC-30

- 本機係依IEC標準製作，採箱型的設計，能防止外光影響，使色合的調整管理有所依據。
- 本機又稱對色燈，使買賣雙方對顏色的判別能有所依據。
- This tester is made in accordance with IEC and certified the minimum interference of the ultra light.
- This machine is also called Contrastive Light which is a good reference of judging colors for both of buyer and seller.

光源 Light source	D光源：又稱北窗光源，為標準光源，色溫7500K A光源：夕陽光源，又稱精密鎢絲燈泡光源，色溫2850K UV光源：紫外線光源 F光源：高效能日光燈光源 D Light: North Sky Daylight (Standard Light Source) A Light: Incandescent, Flame Light UV Light: Ultra Violet Lamps F Light: High Energy Fluorescent Lamp
內徑 Test chamber	70(W) x 53(D) x 35(H) cm
重量 Net weight	26 kg
材積 Dimension	72(W) x 57(D) x 56(H) cm

HT-8136



## HT-8025 PAR MARTON TYPE SPECIMEN ADJUSTER

### 試片磨平機

- 本機係用以將各種形狀的試件磨成適當的尺寸，以工作拉力試驗。附把手，可供上下、左右、前後移動。
- This machine is used to grind the surface of a sample and changes the thickness of various kinds of material to suit the physical test such as tensile test. Move specimen by adjusting the wrench to a direction of up/down, right/left, forward/backward.

試件尺寸 Specimen size	最大 Max 45(W) x 13(L) x 5(T) mm
砂輪尺寸 Grinding wheel size	150 x 38 mm36#
馬達 Motor	1/3HP
速度 Speed	2900/3000 rpm at 50HZ/60HZ
工作空間 Available working area	270 x 70 x 15 mm
工作台尺寸 Working table size	440 x 70 mm
材積 Dimension (W x D x H)	60 x 55 x 40 cm
重量 Net weight	約 About 50 kg
電源 Power	1Ø, 110v 6A / 220V 3A
選用配備 Optional	吸塵器 Vacuum cleaner

HT-8025



## HT-2304 DUAL HEAD SPECIMEN ADJUSTER

### 雙磨頭磨片機

- 本機係用以將各種形狀的試件磨成適當的厚度，以供作拉力試驗之用。
- 本機可同時製作兩個試片，以節省您寶貴的時間。
- This machine is used to grind various size of specimen into suitable thickness so as to be used for tensile testing.
- This machine can test two pieces of sample at the same time, which saves your time.

砂輪線速度	12 m/sec
Line speed of grinding wheel	12 m/sec
工作尺寸 Working size	Ø160 x 44 mm
中心高 Height of center	214 mm
工作行程 Testing stroke	20 mm
試片尺寸 Specimen size	長度大於 Length greater than 260 mm 寬度最大 Max. width 36 mm 厚度最大 Max. thickness 8 mm
電源 Power	1Ø, 220V, 50Hz
材積 Dimension (W x D x H)	約 About 106 x 64 x 48 cm
重量 Net weight	約 About 80 kg

HT-2304



## HT-2367 RUB FASTNESS TESTER 耐摩擦試驗機

### SATRA PM8, PM14, BS1006

- 本機係用來測定鞋用皮革人造皮及襯裡等材料，經旋轉式摩擦後，檢查試件是否破損或脫色，藉以判斷其品質優劣。
- 本機以亦可用於測試鞋皮上印刷字體的染色堅牢度。
- 本機分乾式及濕式兩種測試方法。
- This tester is used to measure the quality of leather, artificial leather or linings.
- It also can be used to measure the fastness of printed marking on the leather surface.
- Both methods of dry and wet can be applied on this tester.

試件尺寸 Specimen size	60 x 60 mm, 或 Ø60 mm
荷重 Load	24.5 ± 0.5N 或 7.1 ± 0.2N
羊毛氈墊 Wool felt pad	外徑 Ø25 ± 1mm, 內徑 Ø3 ± 0.5mm, 密度 190 ± 20kg/cm³ (需另購) Outer diameter Ø25 ± 1mm, inner diameter Ø3 ± 0.5mm, density 190 20kg/cm³ (upon extra charge)
羊毛氈旋轉速度 Rotating speed of wool felt pad	150 ± 5 r.p.m.

HT-2367



金屬片尺寸 Size of metal plate	75(L)x65(W)x5(D) mm, 中心圓孔 Ø25 mm
鋁盤尺寸 Size of aluminum disk	Ø50 x 12 mm
電源 Power	1Ø, 220~240V, 50/60Hz
材積 Dimension	約 About 25(W) x 40 (D) x 50(H) cm
重量 Net weight	約 About 35 kg

## HT-8024F PNEUMATIC PUNCH PRESS TESTER

### 氣壓式切片機

JIS K6301, UL1581

- 除了手動切片機外，本公司另提供氣壓式切片機，供貴客選擇。
- Besides hand-driven type, pneumatic type is available for your selection.

空壓源 Pneumatic source	最少 minimum 0.6 MPa Min. Compressed air 6 kg/cm <sup>2</sup> 以上空壓源
切壓出力 Cutting force	10 KN
有效空間 Effective space	260 x 200 x 70 mm
試片厚度 Specimen thickness	10 mm
氣壓缸行程 Cylinder stroke	50 mm
重量 Weight	55 kg
材積 Dimension (W x D x H)	47 x 26 x 60 cm

HT-8024F



## HT-8024 PUNCH PRESS TESTER 試片切片機

JIS-K6301, UL-1581

- 本機係以轉動圓形把手將試件切成各種形狀，以工作拉力、延伸、老化及耐油等的試驗。
- This machine is designed to cut a sample specimen of a specific size by revolving the round wrench. The specimen is meant either for elongation, tensile, aging or oil test.

斬刀 Specimen cutter	1,2,3# or A,B type可選擇 (selectable)
有效工作區域 Available working area	30 x 16 cm
切斷方式 Pressurization	手動操作 By manual operation
鉗板尺寸 Pressure plate	230(L) x 125(W) cm
墊板尺寸 Pad board	300(L) x 150(W) cm
材積 Dimension (W x D x H)	約 Approx. 45 x 45 x 70 cm
重量 Net Weight	約 Approx. 60 kg.

HT-8024



## HT-8024D HYDRAULIC PUNCH PRESS TESTER

### 油壓式切片機

油壓源 Hydraulic source	10 MPa
切壓出力 Cutting force	Max. 30 kN
有效空間 Effective space	30(L) x 22(W) x 8(H) cm
試片厚度 Specimen thickness	100 mm
油壓缸行程 Ram stroke	80 mm
材積 Dimension (W x D x H)	約 About 42 x 56 x 74 cm
重量 Weight	約 About 100 kg

HT-8024D

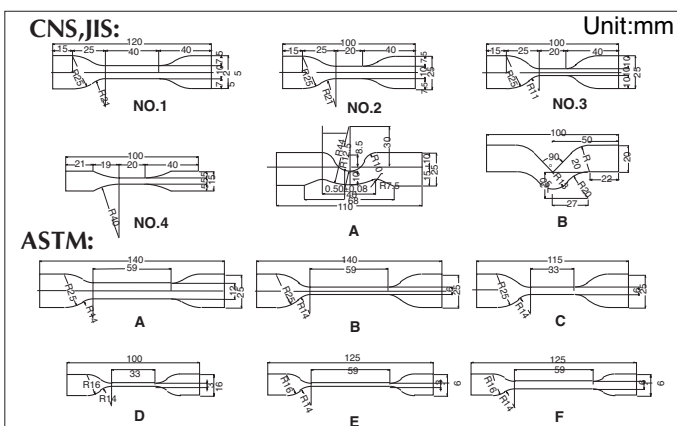

## DUMB-BELL CUTTERS 斬刀

- 常用斬刀如左圖，另有其他規格可接受訂製。
- Aside cutters are our standard ones. Besides, we accept any other special dimensions upon extra charges.

## HT-8355 REBOUND RESILIENCE TESTER

### 反撥彈性試驗機

#### JIS K-6301

- 本機係用來測試加硫橡膠的反撥彈性，藉以制定橡膠試件品質的良窳。
- This machine is to test the rebounding flexibility of vulcanized rubber. The method is to move the iron post, set scale at 100 position. Then make iron post drop down freely. The rebound height for the 4th striking will be the bounding flexibility rate of sucl specimen.

試件尺寸 Specimen	Ø28.68~29 mm, 12.7 mm 高 height
鐵杵 Iron post	Ø12.7 mm, 356(L), 6.35(R) mm
重量 Weight	350g
水平尺 Horizontal length of scale	100 mm (100 graduations)
垂直尺 Vertical height of scale	100 mm
落下高度 Drop height	2000 mm
懸吊鋼絲長度 Length of hanging wire	2000 mm 前後距離：250 mm 左右距離：900 mm 2000 mm (front & rear distance: 250 mm) (right & left distance: 900mm)

HT-8355



## HT-8355V VERTICAL REBOUND RESILIENCE TESTER

### 垂直式反撥彈性試驗機

#### ASTM D263

- 本機係用以落錘垂直自由落下的方式來試驗橡膠的彈性。落錘自特定之高度落下，前三次之結果不計，記錄第4~6次的結果，並求其平均值。
- This tester uses the vertical free falling of hammer to test the features of vertical rebound resilience for rubber specimen. Hammer falls freely from a certain height. The first three tests are ignored, and the test results from the forth to sixth tests should be recorded down and so to get the average.

落錘重量 Weight of hammer	28 g
落下高度 Falling height	400 mm
試片厚度 Thickness of specimen	12.5 mm
材積 Dimension	30 x 30 x 55cm
重量 Weight	9 kg

HT-8355V



## HT-8356 COMPRESSION TESTER OF MAN-MADE SOLINGS

### 泡棉潛變試驗機

#### ASTM D395-03

- 本機係用來測試泡棉在一定時間內持壓的抗壓性，藉由外力消除後，泡棉的伸縮性來判斷其品質的良劣。
- Usage: This apparatus is to determine the ability for the materials of man-made solings to withstand compression under a constant load for a period of time.

加壓 Load	5-150 kgf available
百分錶 Thickness gauge	0.01-50 mm
圓盤 Dia. 10cm disk plate	6片 6 pcs
有效行程 Efficient stroke	超過100 mm greater than 100 mm
材積 Dimension	30(W) x 30(D) x 60(H) cm
重量 Net weight	15 kg

HT-8356

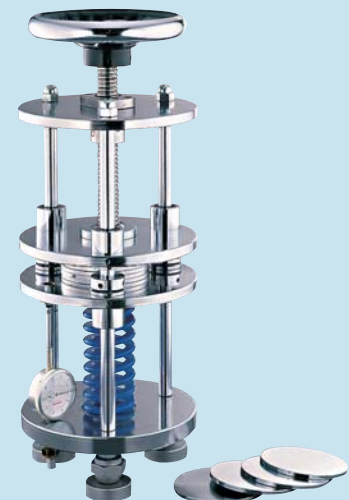

## HT-2369 RESILIENCE ELASTICITY TESTER

### 彈性試驗機

DIN 53512, ISO 4662

- 本機係用來測試彈性與發泡材料之耐衝擊特性。除了藉以觀察不同材料間的差異性之外，亦可得知材料老化之後，其彈性方面的變化，以作為材料採購的依據，或品質改進、研究的參考。
- This tester is used to measure the impact resistance of elastomers and flexible cellular materials. The test results of this tester can be used for understanding the differences between different materials, and can be used to measure the change of elasticity after specimen being aged. This would be a good reference for purchase or for quality research and improvement.

容量 Capacity	0.5J, 0.2J
標示刻度 Scale value	1%
顯示範圍	
Range of display	0~100%
刻度值 Scale value	1 mm
落下角度 Impact angle	90°
擺臂長度	
Length of pendulum	200 mm
衝擊速度 Impact speed	2 m/sec
試件可調整厚度範圍	
Adjustable range for specimen thickness	0~60 mm
彈性體測試裝置	衝擊容量 Impact energy : 0.5 J
Test device for elastomers	球體直徑 Diameter of sphere : 15 mm
發泡測試裝置	形狀 A: 球體直徑: 30 mm
Test device for flexible cellular materials	Shape A: Diameter of sphere: 30 mm 形狀 B: 圓柱體直徑: 40mm, 圓形端半徑: R40mm Shape B: Diameter of cylinder: 40mm, radius of round edge: 40 mm
材積 Dimension	約 About 65(W) x 13 (D) x 35(H) cm
重量 Net weight	約 About 35 kg

HT-2369



HT-8354

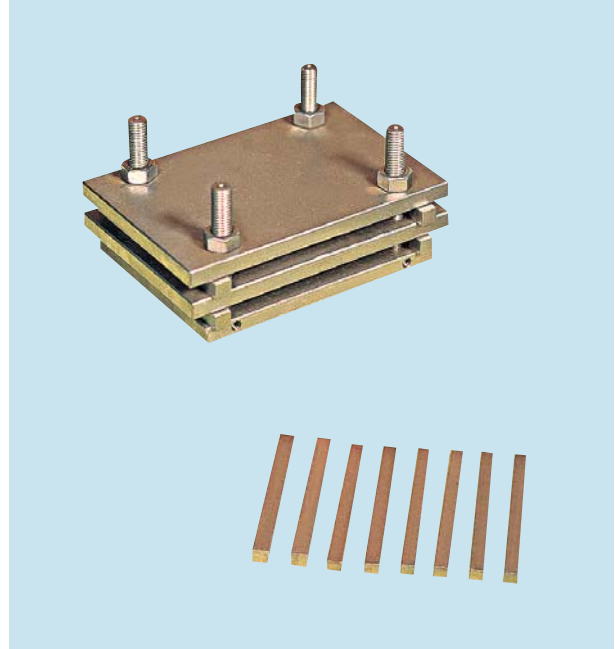

## HT-8354 COMPRESSION AND DEFORMATION TESTER 永久壓縮歪試驗機

CNS-3560,10487 JIS-K6301 ASTM-D395 GB-7759

- 本機係一靜態試驗橡膠在熱環境下的耐壓程度。將試件置入壓板中，鎖上螺絲至適當位置。置入恆溫箱中一段時間，取出冷卻30分鐘，再量取其厚度。
- This is a static way to test the rubber compression under heat. Place the specimen between plates and screw the bolts to a fix position. Put the specimen into the oven for a certain period of time. After finishing the test, take out the specimen and cool for 30 minutes. Measure the post-test thickness.

加熱時間：70°C-22小時 100°C-70小時

HEATING TIME 70°C-22Hr 100°C-70Hr

試件硬度 Hardness Of specimen	Compression	Thickness of
ASTM	JIS	壓縮率 Rate
45 以下 BELOW	40 以下 below	壓板厚度 Platens
45-65	41-60	40% 7.62 mm
65-85	61-80	30% 8.89 mm
85 以上 above	81 以上 above	25% 9.52 mm
		20% 10.16 mm

### 計算公式 Calculation formula:

$$\frac{\text{試驗前試件厚} - \text{壓板厚}}{\text{試驗前厚度} - \text{隔板厚度}} \times 100$$

$$\frac{\text{thickness before} - \text{thickness after}}{\text{thickness before} - \text{thickness of plate}} \times 100$$

試件 Specimen (LxWxH)	橡膠 Rubber-Ø28.68 mm 高 Height-12.7 mm
材積 Dimension	發泡塑膠 Foam plastic 50 x 50 x 25
重量 Net weight	20 x 12 x 10 cm 11 kg

## HT-2368 IRON NAIL DETECTING TESTER 鐵質釘檢知器

- 暗藏在鞋子、衣服、橡膠、木材、食品、玩具等物件中，如鐵釘、鐵屑、縫衣針、鐵扣等細小的金屬物，在處理時極易傷及使用者的手指，甚或流血，故處理前必須予以清除。
- 本機操作十分方便，只要含有金屬物的物件通過檢知器上端，就會亮起紅色燈光，並響起蜂鳴聲，提醒操作者加以注意。
- The iron nail, staples, needles, buckles, metal chips...etc hidden or built-in shoes, clothing, rubber, wood, food, toys...and so on often makes your finger pain or blood while you are processing for it, and so it is absolutely necessary to get rid of it before you start your process.
- This tester is easy to operate. If you put something with metal tiny stuffs inside through the top of detector, LED alarm lights and the buzzer starts to ring immediately.

檢知距離	鐵釘8 cm，鐵器30 cm
Detecting distance	8 cm for staples, 30 cm for iron stuffs
警報方式	紅色發光二極體與蜂鳴器
Method of alarm	Buzzer & red LED
電源 Power	交直流兩用1Ø，220~240V，50/60Hz 或 DC6V Both AC/DC feasible, 1Ø, 220~240V, 50/60Hz or DC6V
材積 Dimension	約 About 21 (W) x 37 (D) x 4 (H) cm
重量 Weight	約 About 10 kg

HT-2368



## HT-2365 INSOLE BACKPART STIFFNESS TESTER 皮鞋勾心剛度試驗機

BS 5131/ 418, QB/T 1812, 1813 SATRA PM59, PM88

- 本機系用來測試皮鞋勾心的縱向抗彎強度。測試時，將鞋後幫端固定，前端掛上砝碼使試件變形，量取勾心的彎曲撓度，作為計算抗彎強度的依據。
- This tester is used to measure the stiffness of steel shank at the waist area of shoes. Fasten the shank at its heel end and apply given load at the other one to bend the specimen. Measure the scale of bending as the basis to calculate flexing resistance of shank.

撓度表	0~10 mm，最小刻度：0.01 mm
Dial Gauge	0~10 mm, Mim. reading : 0.01 mm
下夾爪長 Depth of lower jaw	32mm
下夾爪前傾角	
Declining angle of lower jaw	10°
下夾爪座可調角度	
Rotating angle of lower jaw base	30°
前端夾板厚度 Depth of front-end clamp	12 mm
量卡長度 Length of measuring clipper	60 ± 0.02 mm
砝碼 Load	200 ± 1g，x 4 個 pcs
材積 Dimension	35 x 15 x 30 cm
重量 Weight	12 kg

HT-2365

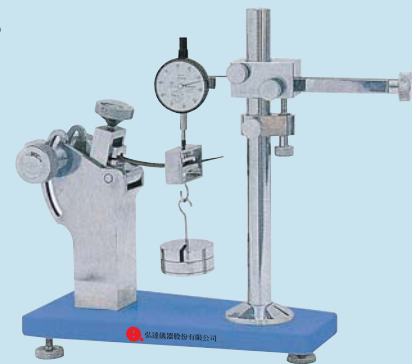

## HT-2380 COMPUTER SYSTEM NON-SLIP PROPERTY TESTER 電腦系統鞋子止滑試驗機

ASTM D1894

- 本機是用來測試鞋底摩擦，來判定其鞋子的止滑性，鞋底的製作是由不同成份膠料混練，或因止滑劑添加數量、種類不同，使測試時，產生摩擦係數的不同，亦可做出比較來做為研發配料之依據。
- This machine is for testing of coefficients' friction of sole and determines non-slip property of shoes. The sole is made of different compounding rubber materials with different amounts of additive. Due to different rubber materials and different amounts of additive or with various additives, it is also capable of making comparison among different coefficients of friction as the base of developing the compound.

HT-2380

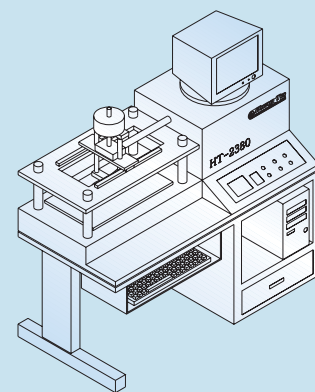

測試速率 Test Speed	50~250 mm/min
測試行程 Test Travel	200 mm
摩擦台面 Friction Platform	600 x 250 mm
荷重 Load	1 kg x 1, 2 kg x 2, 5 kg x 1, 10 kg x 2
路面 Surface of Road (自備 Prepared by customer)	水泥 瀝青 木板 (路面自由加溼)
體積 Dimension (W x D x H) cm	主機 Main Unit : 145 x 60 x 150 電腦櫃 Computer cabinet: 60 x 65 x 130
馬力 Motor	DC 1/2 HP
電源 Power	1Ø, AC 220V, 10A
重量 Weight	280 kg
配備 Accessory	電腦系統一套 Computer x 1

## HT-2337 HEEL PULL-OFF TESTER

### 鞋跟拉脫試驗機

#### SATRA PM113

■ 本機係以手輪逐漸施力的方式，來測試女鞋鞋跟的黏著強度，作為品質進一步改良的參考。

本機亦可量測中高跟女鞋三項重要的特點：

1. 鞋跟部的強度。
2. 分離鞋跟所需的力。
3. 在鞋跟處施以一後向力時，鞋跟部位的變形情形。

■ This tester is used to test the heel adhesion resistance of lady's shoes by manual loading on a hand wheel, in order to be the reference of product improvement.

There are three important features this tester can measure for lady's high-heel shoes:

1. Strength of heel part.
2. The force needed to separate heel.
3. When a backward force applies on the part of heel, how the heel deforms.

量測錶 Capacity	0~100 kgf
作動方式 Method of loading	手動旋轉調整 Manual hand wheel
材積 Dimension	約 About 72(W) x 34(D) x 43(H) cm
重量 Weight	約 About 25 kg

HT-2337



## HT-2322 FINISH HEAT RESISTANCE TESTER

### 防熱接觸實試儀

#### ISO 882-1:1998(E), ANSI Z41-1999, SATRA PM49

■ 本機係用來測試鞋類防熱接觸的情形。

■ This tester is used to measure the heat resistance of shoes.

受熱面積 Heated area	650 ± 50 mm <sup>2</sup>
溫度計 Thermometer	300 ± 2°C
承受壓力 Pressure underwent	20 ± 2 kpa
電源 Power	1Ø, 220V, 50Hz, 3A
材積 Dimension	約 About 105(W) x 42(D) x 55(H) cm
重量 Weight	約 About 170 kg

HT-2322



## HT-8135 SCORCH TESTER 耐昇華試驗機

■ 將試件置於固定溫度之熱板間，於固定時間後，取出試件，冷卻4小時後，與灰色標比對，藉以判定其染色耐昇華等級。

■ Compress the specimen for certain period at requested temperature. Take out and cool for 4 hours. Then compare with the gray scale.

測試方法 Testing method	溫度 Temperature(°C)	時間 Time(s)
A	150+/-2	30
B	180+/-2	30
C	200+/-2	30

試件尺寸 Specimen	100 × 40 mm
加熱板 Heating plate	120 × 60 mm
壓力 Pressure	40+/-10g/cm <sup>2</sup>
溫度 Temperature	Rt-300°C(Suggestive temp.150, 180, 200°C)
材積 Dimension	43 × 55 × 36 cm
重量 Weight	22 kg

HT-8135



## HT-2317 LACQUER RESISTANCE TESTER

### 鞋電阻測試儀

GB 4385-1995, ISO 8782-1:1998

- 本機係用來測試鞋類耐電阻的情形。
- This tester is used to measure the resistor resistance of shoes.

輸出直流電壓 Output DC voltage	100 ± 2V
精度 Accuracy	5%
內電極材料 Inner electrode material	Ø5 mm 鋼珠 steel ball · 4 kg
外電極材料 Outer electrode material	鋼板 Steel board
電源 Power	1Ø, 220V, 50Hz, 3A
材積 Dimension (W x D x H)	約 About 105 x 42 x 55 cm
重量 Weight	約 About 170 kg

HT-2317



## HT-2318 SHOE DIELECTRIC RESISTANCE TESTER

### 成鞋耐電壓試驗機

GB 12011-2000, ISO 8782-1:1998

- 本機係用來測試鞋底材料或絕緣鞋材，在施以一定之電壓值，並持續一段特定時間後，以其所能承受的電壓值，來決定其耐電壓的特性。
- 本機採立式設計，符合人體工學。
- This tester is used to measure the shoe material or insulated shoe material by using a certain voltage value for a certain period of time to see the dielectric withstanding character.
- This tester is of vertical design in accordance with human ergonomics.

容量 Capacity	0.5 kVA
測試電壓加壓速度 Increasing speed of test voltage	1KV/sec 到指定電壓值 1KV/sec to appointed voltage value
輸入電壓 Input voltage	AC 220V
輸出電壓 Output voltage	0~20KV AC
導電鋼珠直徑 Diameter of conductive steel ball	Ø3 mm
內電極鋼珠層深度 Depth of inner electrode steel layer	30 mm以上 above 30 mm
金屬網試驗盤尺寸 Size of metal mesh test plate	40 x 20 mm
測試頻率 Test frequency	60Hz
測試時間 Test time	1 分鐘 minute
測試空間 Test space	58 x 38 x 54 cm
電源 Power	1Ø, 220V, 0.6 mA
材積 Dimension (W x D x H)	約 About 120 x 50 x 160cm
重量 Weight	約 About 90 kg

HT-2318



HT-2336



## HT-2336 SOLE ADHESION TESTER 鞋尖剝離試驗機

SATRA AM4, AM5, BS 5131 : 4.6/5.1

- 本機係用來檢驗鞋子的剝離性能。
- This is to measure the adhesion resistance of shoe soles.

力量範圍 Range of force	鞋尖 0~450N Shoe tip 0~450N 鞋跟 0~900N Heel 0~900N
材積 Dimension (W x D x H)	約 About 130 x 15 x 25 cm

**HT-2303 DIGITAL ADHESION TEARING TESTER 數字剝離儀**
**GB/T3903.3-94**

- 本機係用來檢驗成鞋鞋底與鞋幫之間的剝離強度。將成鞋裝上鞋楦，固定在剝離儀上，以剝離刀撥開鞋底與鞋幫結合處，其所需之剝離力除以剝離寬度即為剝離強度。
- This tester is used to measure the adhesion tearing strength between shoe sole and quarter. Put shoe mold in finished shoe and affix it on the tester. Use knife to cut apart the shoe sole from quarter. The tearing strength is the force divided by the width of tearing.

最大剝離荷重 Max. tearing load	不小於 Not less than 392N
剝離刀口寬度 Width of tearing knife	10±0.05/20±0.1 mm
定位桿與拉桿距離 Distance between positioning post and test post	不小於 Not less than 50mm
剝離下行速度 Tearing downward speed	20±2 mm/min
千分錶 Micrometer	0.01 ~ 1 mm
線性偏差 Error of linearity	<3%
示值偏差 Error of display value	<3%
示值變動值 Change of display value	<3%
電源 Power	1Ø, 220V, 50Hz
材積 Dimension (W x D x H)	72 x 58 x 80 cm
重量 Weight	約 About 100 kg

**HT-2303**

**HT-2315 ZIPPER TORSION TESTER 拉鍊扭轉試驗機**
**QB/T 2171-2173-2001**

- 本機係用來測試拉鍊頭的扭力強度，作為品質改良的參考依據。
- This tester is used to measure the torsion resistance of zipper head, in order to be the reference of product improvement.

容量 Capacity	50 Kg-cm
精度 Accuracy	±1%
數字顯示 Digital display	HT-9535SA
扭轉速度 Torsion speed	1.5 rpm
電源 Power	1Ø, 220V, 50Hz
材積 Dimension (W x D x H)	約 About 105 x 42 x 55 cm
重量 Weight	約 About 170 kg

**HT-2315**

**HT-2309 SLIDE FASTENERS RECIPROCATING TESTER**
**拉鍊往復拉動儀**
**CNS 1083, QB/T 2171**

- 本機係用來測試拉鍊在橫向及縱向的作用力下，是否可以承受所規定的來回拉動次數。試驗時本機以30rpm的定速度拉動拉鍊拉頭到規定的拉動次數後停機，再檢視拉鍊的受損情形。
- This tester is used to measure the resistance of zipper under lateral and vertical reciprocating force. During testing, move the zipper puller back and forth under the fixed speed 30 rpm to a certain cycle and then inspect how the zipper breaks.

橫向夾具寬度 Width of lateral grip	25 mm
縱向夾具重量 Weight of vertical grip	0.28~0.34 kg
兩縱向夾具距離 Distance between two vertical grips	6.35 mm
往復行程 Reciprocating stroke	75 mm
往復次數 Reciprocating cycle	30 cpm
試件閉合角度 Specimen closing angle	60°
試件開啓角度 Specimen opening angle	30°
計數器 Counter	6位數LC 6-digit LCD display
馬達 Motor	1/4 HP
電源 Power	1Ø, 220V, 50Hz
材積 Dimension (W x D x H)	約 About 30 x 55 x 68 cm
重量 Weight	約 About 35 kg

**HT-2309**

## HT-2319 WATER PENETRATION TESTER 耐滲水試驗儀

HG/T3664-2000 ISO 8782-1-1998

- 本機係以充氣法或浸泡法來測試膠面鞋(靴)的耐滲水特性。
- 充氣法：將試驗鞋(靴)口密封，充入定量的空氣後浸入水中，使水面與鞋(靴)口距離小於75mm，在一定時間之後，再觀察鞋(靴)表面是否有氣泡形成。
- 浸泡法：將試驗鞋(靴)浸入水中，使水面與鞋(靴)口距離小於75mm，在一定時間的浸泡之後，取出並檢查鞋(靴)內是否有水滲入。
- This tester adopts two methods to measure the water penetration characters of footwear.
- Air-filling method: Seal shoe sample and fill it with a certain quantity of air in order to make sample sink in water and make the distance from water level to the open of shoe less than 75mm. After a certain period of time, check if there is any bubbles on the surface of shoe.
- Soaking method: Soak shoe sample in water and make the distance from water level to the open of shoe less than 75mm. After a certain period of time, check if there is any water penetrating into the shoe.

試片數 Number of specimen	2 pcs (4 pcs選用)
空氣壓力 Pneumatic pressure	0-50kpa 或依客戶指定 0-50kpa or as requested
空壓機 Air compressor	客戶自備(選用) to be prepared by customer (or optional)
夾具上下行程 Vertical stroke of grips	320 mm
計數器 Counter	6位數LC 6-digit LCD display
電源 Power	1Ø, 220V, 2A
材積 Dimension (W x D x H)	約 About 125 x 55 x 155 cm
重量 Weight	約 About 128 kg

HT-2319



## HT-2321 WATER VAPOUR PERMEABILITY TESTER 透氣實驗儀

ISO 8782-1-1998

- 本機係在規範規定的20°C及65%RH的環境下，測試鞋面及上層鞋材(含皮面及襯裡)耐水蒸氣滲透的特性。
- This tester is used to measure the character of water vapor permeability of shoe leather or upper materials of shoes under the circumstance of 20°C temperature and 65%RH humidity.

測試環境 Ambient circumstance	溫度20°C，溼度65%RH Temperature 20°C, Humidity 65%RH
瓶口直徑 Diameter of bottle	約 About Ø 30 mm
試驗盤轉速 Speed of rotating drum	75 ± 5 cpm
試件尺寸 Size of specimen	Ø 34 mm
風扇尺寸 Size of fan	90 x 75 mm x 3 pcs
風扇數 Number of fan	3 pcs
風扇角度 Angle of fan	與軸心平行成 120° parallel to axle
風扇速度 Speed of fan	1400 cpm
風扇與試件距離 Distance between fan & specimen	最大 Maximum 15 mm
電源 Power	1Ø, 220V
材積 Dimension (W x D x H)	約 About 137 x 90 x 90 cm
重量 Weight	約 About 160 kg

HT-2321



## HT-2324 FREEZING TESTER 防寒試驗儀

ISO 8782-1:1998

- 本機係用來測試鞋類的防寒情形。
- 測試方法是將熱電偶固定於鞋墊中央，鞋內置滿鋼珠。冷凍箱降溫至-20°C，置入鞋子，調整支架讓鞋子的上緣與絕緣箱的開口等高，再以隔熱板將冷凍箱的開口密封。最後，記錄鞋墊溫度在30分鐘內隨時間的變化。
- This tester is to measure the freezing resistance of shoes.
- The testing method is to put thermo couples at the center of shoe pad and put steel balls inside the shoe sample. Freeze the chamber to -20°C and put shoe sample inside. Adjust the racket in order to make the upper edge of shoe sample is as the same level as chamber, then use insulating board to seal the open of chamber. Please record the change of temperature of shoe pad for the last 30 minutes.

箱內尺寸 Chamber size	50 x 50 x 60 cm
溫度範圍 Temperature range	RT~-30°C
鋼球直徑 Diameter of steel ball	Ø5mm
電源 Power	1Ø, 220V, 50Hz, 3A
材積 Dimension (W x D x H)	約 About 105 x 42 x 55 cm
重量 Weight	約 About 170 kg

## HT-2325 HEAT CONDUCTIVITY TESTER OF FOOTWEAR

### 隔熱實試儀

ISO 8782-1:1992

- 本機係用來測試成鞋鞋底的耐熱程度。將沙箱加熱至150°C，鞋子置入，讓沙子掩蓋製鞋面與鞋底接觸處，再記錄鞋墊溫度在30分鐘內隨時間的變化情形。
- This tester is used to measure the heat resistance of shoes. Heat the sand bath up to 150°C, put the shoe sample on. Make sand to cover the line between shoe leather and shoe sole. Record the change of temperature for the last 30 minutes.

鋼球直徑 Diameter of steel ball	Ø5 mm x 4 kg
沙箱溫度 Temperature of sand bath	150°C
測試區域 Test area	250 x 460 mm 250 x 460 mm
熱板最大溫度 Maximum temp. of heat board	250°C
溫度記錄配件 Media of recording temp.	溫度記錄器 Temperature recorder
耗電量 Power consumption	2.5 KW
電源 Power	1Ø, 220V, 50Hz
材積 Dimension (W x D x H)	約 About 105 x 42 x 55 cm
重量 Weight	約 About 170 kg

## HT-8150A LOW TEMPERATURE BRITTLENESS TESTER

### 低溫脆化試驗機

ISO 812, ASTM D746, GB/T 15256

- 本機係將試件浸泡在特定低溫的冷媒中至 2.5分鐘（橡膠3分鐘）後，加以撞擊，再觀察適件是否斷裂，藉以判斷材料耐低溫脆化的特性。
- 冷媒為液態物質，可使用酒精或乾冰，但請由客戶自備。
- This tester is to soak specimen in a certain type of refrigerant under a given low temperature for 2.5 minutes (3 minutes for rubber) and then impact specimen to see if it ruptures, so as to measure the brittleness resistance under low temperature.

溫度範圍 Range of temperature	Rt~-70°C
冷媒 Refrigerant	由客戶自備 To be prepared by user
試片尺寸 Size of specimen	橡膠 40 x 6 x 2mm, 塑膠 38 x 6 x 2mm Rubber: 40 x 6 x 2mm, Plastic: 38 x 6 x 2mm
撞擊錘半徑 Strikers radius	R 1.6±0.1mm
電源 Power	1Ø, 220V, 50/60Hz, 8A
材積 Dimension	約 About 60 x 85 x 60 cm
重量 Weight	約 About 120 kg

HT-2324



HT-2325



HT-8150A



## HT-8362D HYDROSTATIC TESTER

### 電子式耐水壓試驗機

JIS K6328, L1092, ISO 811, DIN 53886, BS 2823, AATCC 127

- 本機適用於纖維布、不織布、防水布、皮革、人造皮等材料之耐水壓測試。傳統之水柱試驗方法，操作不便，機台又佔空間。本機採桌上型設計，不佔空間，並使用壓力傳感器感應，配合電子數字 LCD 顯示，可顯示瞬間值及最大值，不但操作方便，更可透過列表機將測試結果列印出來。
- This machine is used to test the hydrostatic resistance for the materials of fabric cloth, non-woven cloth, waterproof cloth, leather, artificial leather...etc. Traditional design with a high water post is not easy to use and waste a lot of space. This tester is of bench-top design, compact size with an LCD digital display, not only convenient to use and read, but also the test result can be printed out via a dot matrix printer (optional).

壓力範圍 Pressure range	5~50000 mmH <sub>2</sub> O (0.0005~5kg/cm <sup>2</sup> )
解析度 Resolution	5 mmH <sub>2</sub> O (0.0005kg/cm <sup>2</sup> )
準確度 Accuracy	Better than ±1%以內
夾持內徑 Clamping diameter	Ø113 mm
加壓速度	
Pressurize speed	5~180ml/min (1kg/cm <sup>2</sup> /min) adjustable 可調
試片面積 Sample area	100 cm <sup>2</sup>
水容量 Water capacity	300 ml (cc)
顯示方式 Method of display	電子數字 LCD 顯示 digital display
電源 Power supply	1Ø, 220V, 50/60Hz 3A
重量 Weight	120 kg
材積 Dimension (W x D x H)	70 x 45 x 60 cm

HT-8362D



## HT-8622 HEAT GRADIENT TESTER 熱傾斜試驗機

- 本機係產生熱傾斜的效果，來測試包裝材料的熱封性，或求取布料或皮革的最大耐熱溫度。
- This apparatus produces heat gradient for measuring the heat seal of packing materials or to find the optimum temperature of test resistance of cloth and leather products.

溫度 Temperature	Rt~+200°C, RT-200 degree celsius
壓力 Pressure	0~4 kg/cm <sup>2</sup> , 0-4 kg/cm.sq
試件 Specimen	20 x 30 mm
熱板間隔 Interval of heating plate	20 mm
加熱板數 No. of heating plate	5組, 5 pieces
材積 Dimension (L x W x H)	60 x 50 x 85 cm
重量 Net weight	約 Approx. 70 kg
電源 Power	1Ø, 220v

HT-8622



## HT-8037 STANDARD LAUNDRY TESTER

### 染色耐洗試驗機

- 將試件與鋼球置入試驗杯中，並在規定的溫度及時間內進行水洗。取出試件與灰色標比對，以判定其耐水洗堅牢度。
- Put specimen and steel ball into the testing cup and have the specimen laundered under requested temperature within certain period. Compare with gray scale after completing test.

試件尺寸 Specimen	10×5 cm
溫度 Temperature	Rt~+100°C (建議40, 50, 60, 70, 80°C) R.T-100°C (Suggesting temp 40, 50, 60, 70, 82°C)
速度 Rotation Speed	42±2 RPM/min
試驗杯 Testing Cup	Ø80 mm, 高120 mm, 容量450cc Ø80 mm, H120 mm Capacity 450cc
鋼球尺寸 Steel ball	Ø6.4 mm
計時器 Timer	0~60分, 0-60min
材積 Dimension	110(W) x 70(D) x 134(H) cm
重量 Weight	160 kg

HT-8037



### HT-0601 VISCOMETER 黏度計

- 此粘度計適合不同的產業使用。如油漆、接著劑、重油墨水、食品、化妝品、橡膠、紙漿、化學、石油產品等。使用方便，適用測定粘度及品質管理。
- This is used to measure the viscosity of various solutions for different industries such as paint, rubber, chemical, coal oil, make up products...etc.
- This would be a good reference for product development and improvement.

型式 Type	VT-03 低黏度用	VT-04 高黏度用
黏度測定範圍 Testing range	2-33, 15-150, 50-330 CP	0.3-13, 3-150, 100-4000 P (1P = 100CP)
迴轉速度 Rotating speed	62.5 rpm	
電源 Power	DC 1.5V x 4乾電池 battery (亦可選配使用變壓器 optional AC adopter)	
重量 Weight	約 580g	
材積 Dimension	18 x 10 x 4 cm	

HT-0601



### HT-8187 BALANCE 電子天平 (比重用)

型式 Model	200D	310S
容量 Capacity	210g	310g
解析度 Resolution	0.001g	0.01g
比重解析度 Density resolution	0.001	
材積 Dimension	210 x 317 x 86 mm	188 x 250 x 70 mm
重量 Weight	3.8 kg	5.8 kg
電源 Power	110 / 220V (supplied with AC adapter附變壓器)	

HT-8187



200D



310S



### HT-8137 PERSPIRATION TESTER 耐汗試驗機

#### ISO 105E04, AATCC-RR52

- 將試件置於人工汗液中完全浸泡30分鐘，以砝碼施重，並於37°C的恆溫箱中放置4小時後，再取出，對照灰色標，以判斷其耐汗級數。
- 本機適用之對象包括各種纖維布料及鞋材織物等。
- Wholly and evenly immerse the test sample in artificial sweat liquid for 30 minutes and apply with load. Place it in an oven exposed under the temperature of 37°C for 4 hours. Take it out and compare it with gray scale to determine its grade of perspiration resistance.
- This tester is used for varieties of fiber fabric and footwear cloth.

型式 Type	JIS	AATCC
試片尺寸 Sample size	6 x 6 cm 或 or 10 x 4 cm	
壓克力板 Acrylic plate	115 x 63 x 3 mm x 10片 pieces	
荷重 Load	4.5 kg	8 Lbs
重量 Weight	17(W) x 8(D) x 19(H) cm	25(W) x 8(D) x 19(H) cm
體積 Dimension	6 kg	6 kg

HT-8137



JIS

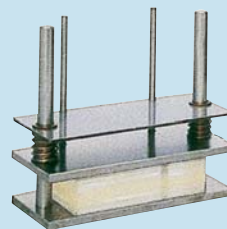

AATCC

## HT-2132A GRAY SCALE FOR COLOR CHANGE

### 變褪色灰色標

- 變褪色灰色標：用以比對染色堅牢度試驗後，試片之變褪色的程度。
- GRAY SCALE FOR COLOR CHANGE: used to compare the sample and see the condition of the color change after the dyeing fastness test.

## HT-2132B GRAY SCALE FOR STAINING 污染灰色標

- 污染灰色標：用以比對染色堅牢度試驗後，白棉布之污染的程度。
- GRAY SCALE FOR STAINING: used to compare the white cotton cloth to see the condition of the staining after the dyeing fastness test.

等級 Grade	5, 4~5, 4, 3~4, 3, 2~3, 2, 1~2, 1
體積 Dimension	60×235 mm

## HT-2132C 9-STEP CHROMATIC TRANSFERENCE SCALE 六色九級卡

CNS-4452, JIS-K6382, K6401, K6767

- 本卡係用來比對在測試過染色堅牢度之後，試片及白棉布之變褪色或污染的程度。
- This scale is used to compare the sample or the white cotton cloth to see the condition of the color change or staining after the dyeing fastness test.

等級 Grade	5, 4~5, 4, 3~4, 3, 2~3, 2, 1~2, 1
體積 Dimension	165×240 mm

## HT-8184V VOICE NAVIGATION & CUSTOM PH METER

### V型精密PH酸鹼測定計

規格 Specifications	HM-30V	HM-35V	HM-40V	HM-50V	HM-60V
量測方式 Measuring method	玻璃電極方式 glass electrode method				
顯示 Display (digital)	pH/mV/temp.				
溫度補償 Temp.compensation range	0 to 100°C (Automatic or manual) (自動或手動)				
範圍 Range	pH		pH0-14		pH0-14
resolution 解析度	0.01pH		0.01pH		0.001pH
mV	0-±1,999mV		0-±1999mV		0-±1999.9mV
resolution 解析度	1mV		1mV		0.1mV
temperature	0 to 100°C				
resolution 解析度	0.1°C				
重複性 Repeatability	pH		±0.01 pH±1digit		±0.001 pH±1digit
mV	±1mV±1digit		±1mV±1digit		±1mV±1digit
temp	±0.1°C±1digit				
輸出 output	pH		±700mV(pH 0 to 14)		±1V(0 to ±1,999mV)
mV	±1V(0 to ±1,999mV)		±1V(0 to ±1,999mV)		±1V(0 to ±1,999mV)
temp	0-1V(0 to 100°C)				
校正 Calibration	pH1,4,7,9,12 1 to 5 point Cal. Other 2 kinds of standard solution are usable.				
列表機 Printer	—		—		built-in
介面 RS-232C	—		option		built-in
電源 Power requirement	AC line 50,60Hz(with use of AC adapter)				
耗電 Power consumption	16VA		17VA		18VA
操作溫度 Operating temp	0 to 40°C				
材積 Dimension	226(w) x 109(h) x 306(d) mm				
重量 Weight	2.3kgs	2.3kgs	2.5kgs	2.5kgs	2.5kgs

## HT-8191 THERMOMETER 表面溫度計

型式 Model	TM-305(1 probe)	TM-307(2 probe)
感溫棒 Probes	Type K	
量測範圍 Measuring range	-50°C ~1300°C	
精度 Accuracy	-50°C~+1000°C±0.3%	
電源 Power supply	乾電池006p(9V) Battery 006p(9v)	
電池壽命 Battery life	約200小時 Approx. 200 hours	
材積 Dimension	140(H) x 65(W) x 30(D) mm	
重量 Net weight	275g.	

## HT-2132A



AATCC (made in U.S.A)



JIS (made in Japan)

## HT-2132B



AATCC (made in U.S.A)



JIS (made in Japan)



## HT-2132C



## HT-8184V



## HT-8191



## HT-8189 THICKNESS GAUGE 厚度計

型式 Model	SM-112	SM-114	SM-113	SM-150	B-150
最小刻度 Min graduation	0.01 mm				
測試範圍 Test range	10 mm				
測試深度 Test depth	20 mm	120 mm	150 mm	427 mm	150 mm
材積 Dimension	102×90×15	132×183×15	141×216×15	162×514×15	200×310×240
重量(約) Net weight	160g	270g	440g	1460g	6000g

HT-8189



SM-112

SM-114



B-150



## HT-8188HF HYDRAULIC FRAME TESTER FOR DUROMETER

### 硬度計油壓試驗基座

## HT-8188MF FRAME TESTER FOR DUROMETER 硬度計試驗基座

- 攜帶式硬度計固然使用方便，但卻常因每個人施力不同，而有不同的結果。本機附有砝碼，荷重平均、施力穩定，HT-8188HF更配有油壓緩降機構，可均勻施壓，極具測試上之參考價值。
- Hand-held durometers are convenient to use, but sometimes you get the different data owing to different users. This tester (HT-8188HF) is equipped with hydraulic mechanism and load that gives even and stable loading force.

型式 Model	HT-8188HF	HT-8188MF
荷重 Load	1 kg (optional 1.5, 2, 5 kg 選用)	
試片台尺寸 Diameter of specimen base	59 mm	68 mm
喉深 Testing depth	53 mm	62 mm
未裝硬度計高度 Height without durometer	170 mm	110 mm
材積 Dimension	122 x 217 x 315 cm	117 x 152 x 247 cm
重量 Weight	9 kg	6.5 kg

HT-8188HF

HT-8188MF



## HT-8188 HARDNESS TESTER 硬度計

- 將硬度計直接置於試片上，則硬度計值會直接顯示在指針上。
- Place durometer on the test sample and its hardness value would display on the needle.

HT-8188



GS-701N

GS-702N

GS-706N

GS-709N

ASKER-C

ASKER-F

ASKER-A



型式 Model	符合規範 Applied norms	適用材料 applied materials	重量 Weight
GS-701N	JIS-S6050, SRIS-0101	Sponge, felt, soft rubber, hard foam, bobbin winding, potter's clay 海綿、毛毯、軟質橡膠、硬質發泡膠、管紗、陶土	200g
GS-702N	ASTM-D2240D, ISO-R868D, JIS-K7215D	Hard plastic, hard rubber, soft plastic 硬質塑膠、硬質橡膠、軟質塑膠	
GS-706N	JIS-K6301A	General rubber 一般橡膠	
GS-709N	ASTM-D2240A, ISO-R868A, JIS-K7215A	General rubber, soft plastic 一般橡膠、軟質塑膠	
ASKER-C	SRIS-0101	Soft rubber, sponge plastic foam, textile winding 軟質橡膠、海綿、發泡塑膠、紡織線	519g
ASKER-F	高分子計器F型, ASKER-F	Foam rubber, plastic foam 發泡塑膠、發泡橡膠	
ASKER-A	ASTM-D2240A, JIS-K7215A, JIS-K6253	General rubber 一般橡膠	200g



品質·技術·服務

## 弘達儀器股份有限公司

HUNG TA INSTRUMENT CO., LTD.

工廠：臺灣省台中市407工業區11路17號

TEL: 04-23590108 (代表)

FAX: 04-23593110, 23588599, 23591149

E-mail: info@hungta.com

<http://www.hungta.com>

<http://www.hungta.com.tw>

分公司：台北市110忠孝東路五段71巷17號

TEL: 02-27467770

FAX: 02-27686430

分公司：高雄市807三民區金山路305號

TEL: 07-3429618-9

FAX: 07-3427499

REGIONAL AGENT:

## HUNG TA INSTRUMENT CO., LTD.

FACTORY & HEADQUARTERS

NO. 17 11TH ROAD INDUSTRIAL PARK 407

TAICHUNG, TAIWAN

TEL: 886-4-23590108 FAX: 886-4-23593110, 23588599, 23591149

E-mail: info@hungta.com

<http://www.hungta.com> <http://www.hungta.com.tw>

THAILAND OFFICE:

TEL: 662-3120446-8

FAX: 662-3120445

MALAYSIA OFFICE:

TEL: 606-7636031 FAX: 606-7637692

INDONESIA AGENT:

TEL: 62-21-6324602 FAX: 62-21-6324603

VIETNAM OFFICE:

越南公司:

TEL: 84-8-7517821 FAX: 84-8-6670254

東莞公司:

DONGGUAN BRANCH OFFICE:

TEL: 0769-22494695/22494895/22494862 FAX: 0769-2494665

上海公司:

SHANGHAI BRANCH OFFICE:

TEL: 021-56954466/56950650/56950304/56950219 FAX: 021-56377170

廈門公司:

XIAMEN BRANCH OFFICE:

TEL: 0592-5800710/5800711 FAX: 0592-5800713

· 本公司保有變更設計的權利· 如有更改不另行通知·

· NOTE: The specifications are subject to change without notice.

● 版權所有· 翻印必究 ● ALL RIGHTS RESERVED